

Hip Replacement

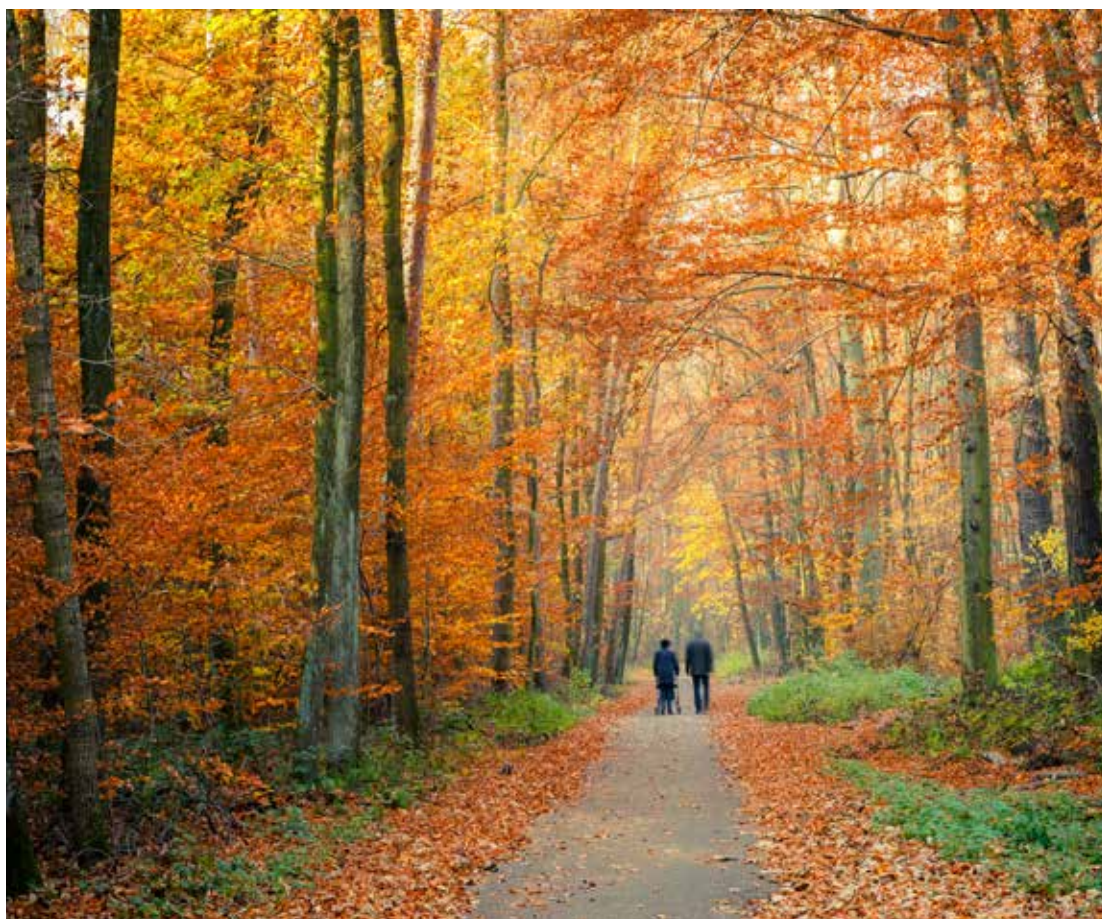

Your name

Surgery date

Your follow-up appointment with your surgeon is:

Date

Time

Surgeon

Phone number

Whom to Call with Questions

If you have questions about your surgery, please call your hospital's phone number listed below.

- Abbott Northwestern Hospital:
612-775-4609
- Buffalo Hospital: 763-684-7753 or call
your surgeon's office for more information
- Cambridge Medical Center: 763-689-8700
- District One Hospital: 507-497-3840
- Mercy Hospital: 763-236-8860
- Mercy Hospital — Unity Campus:
763-236-8860
- New Ulm Medical Center: 507-217-5440
- Owatonna Hospital: 507-977-2277
- Regina Hospital: 651-404-1342
- River Falls Hospital: 715-307-6451
- St. Francis Regional Medical Center:
952-428-2565
- United Hospital: 651-241-5390

Please bring this book to:

- appointments with your surgeon
- your pre-surgery class
- the hospital on the day of surgery
- therapy sessions
- physical therapy appointments.

Important

Be sure to look in the back-pocket folder of this book for more important information!

Watch This!

- Visit allinahealth.org/pt to watch a video on pre-surgery therapy and common activity precautions you can expect after hip replacement surgery.
- Visit ckri-allina.medbridgego.com/access_token/TQMW3DD2 to watch videos on your hip exercises before surgery. Click on "verify access code" to watch the videos.

Worksheets in this book:

- Determining Your Health Insurance Coverage (page 19)
- Before Surgery Exercise Program (page 29)
- Questions to Ask at My Follow-up Appointment (page 69)
- Home Exercise Program (page 81)
- My Medicine List (page 97)

Before Your Surgery

Checklist

- Contact your surgeon's office if you are planning to visit the dentist within 1 month before your surgery.
- Schedule your health history and physical exam. You can read more about this exam on page 15.
- Schedule your pre-surgery education class, if offered at your hospital. You can read more about this class on page 17.
- Select a member of your care circle to be your personal support coach. You can learn more on page 18.
- Review the hospital pre-registration information on page 20.
- Review this education book and all other handouts given to you.
- Review and complete your paperwork, including any surveys.
- Make a list of all your current medicines. The "My Medicine List" is on page 97 for you to fill out.
- Call your insurance provider with any questions you have about your coverage. Use the worksheet on page 19 as a guide.
- Talk with your family, friends and others close to you (your "care circle") about your needs after surgery.

Did You Know?

Your **care circle** is your family, friends and others close to you. This term will be used throughout this book.



Hip Replacement

Eighth edition

Developed by Allina Health

© 2020 Allina Health System

The publisher believes that information in this manual was accurate at the time the manual was published. However, because of the rapidly changing state of scientific and medical knowledge, some of the facts and recommendations in the manual may be out-of-date by the time you read it. Your health care provider is the best source for current information and medical advice in your particular situation.

All rights reserved. No part of this book may be reproduced in any form or by any means, electronic or mechanical, including photocopying, without permission in writing from the publisher.

Disclaimer

This publication is for general information only and is not intended to provide specific advice or recommendations for any individual. The information it contains cannot be used to diagnose medical conditions or prescribe treatment. The information provided is designed to support, not replace, the relationship that exists between a patient and his/her existing physician.

For specific information about your health condition, please contact your health care provider.





Table of Contents

Introduction

Welcome	7
Your Health Care Team	8
The Normal Hip	9
The Problem Hip	10
The Hip After a Hip Replacement.....	11
The Hip After a Hip Resurfacing	12

Chapter 1: Before Surgery

Your Health History and Physical Exam	15
Diabetes	15
Blood Levels Before Surgery	16
Pre-surgery Education Class	17
Personal Support Coach	18
Insurance Coverage	18
Worksheet: Determining Your Health Insurance Coverage	19
Hospital Pre-registration	20
Advance Care Planning	20
Medicine Use Before Surgery.....	21
Worksheet: Medicine Use	22
Quit Tobacco for Your Surgery	23

Chapter 2: Preparing for Surgery

Before Surgery Exercise Program	29
Walking	29
Hip Exercises	30
Worksheet: Before Surgery Exercise Program	32
Mobility and Activity Techniques for Daily Living	33
Breathing Exercises (Respiratory Exercises)	37
Preparing Your Home for Your Needs After Surgery	38
What to Bring for Your Hospital Stay	40
Preparing Your Mind and Body for Surgery	41
Preparing for Surgery	41
The Day Before Surgery	41
Cleansing Your Skin for Surgery	42
Food and Liquid Directions Before Your Surgery	44
The Morning of Surgery	44

Chapter 3: Surgery, Hospital Stay and Beyond

What to Consider About Visitors	47
What to Expect the Day of Surgery	47
Anesthesia: What You Need to Know	48
Pain After Surgery	49
Medicines That May Be Used During Your Recovery After Surgery ...	52
What to Expect During Your Hospital Stay	54
Preventing Problems (Complications)	55
How to Use an Incentive Spirometer	56
Tips to Prevent Falls While You Are in the Hospital.....	57

Chapter 4: Care After Surgery

What to Expect During Your Recovery	61
Commonly Asked Questions	65
Worksheet: Questions to Ask at My Follow-up Appointment	69
Pain Relief	70
Pain Medicine: What You Need to Know.....	71
Anti-inflammatory Medicines	74
Constipation	74
Nutrition: What You Need To Know	76

Chapter 5: Home Exercise Program

Home Exercise Program	81
Swelling.....	82
Strengthening	83
Walking	85
Standing Exercises	86
Additional Exercises	87
Worksheet: Home Exercise Program.....	88

Chapter 6: Resources

Medical Equipment	91
Community Resource Directory	93
Websites.....	95
Notes	96
Worksheet: My Medicine List	97

Introduction

Welcome

Did You Know?

Your **care circle** is your family, friends and others close to you. This term will be used throughout this book.

How do you make your surgery a positive and meaningful experience? Many people and their **care circles** find it helpful to learn as much as they can before surgery.

This book was created to help you prepare for surgery and guide you through your recovery. The information is not meant to replace advice you receive from your health care team.

Please try to read the entire book before your surgery. Read it at your own pace and write your questions in the margins.

Bring this book with you when you come to the hospital for your surgery. Your health care team will work with you and your care circle to create a recovery plan that is right for you. They will be available to answer any questions you have.

Your health care team looks forward to caring for you!

Your Health Care Team

Did You Know?

You can call 612-262-4930 to get more information about the cost of your surgery.

As you prepare for your hip surgery, hospital stay and recovery, your health care team will work with your surgeon to help you along your journey.

Members of your health care team may include doctors, doctor (physician) assistants, nurses, nursing assistants, social workers, case managers, and physical and occupational therapists. You may also be visited by a dietitian, respiratory therapist or chaplain.

The Normal Hip

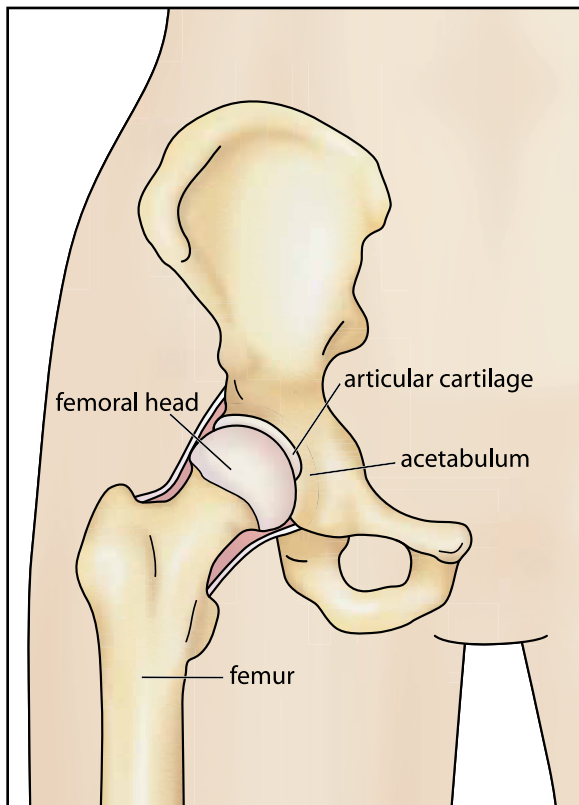

© Allina Health System

In the normal hip, the ball and socket are covered with a smooth layer of tissue (cartilage).

Tip

Visit allinahealth.org/hipreplacementvideo to watch a video with more information about your hip.

The hip is a ball and socket joint. The ball is formed by the head of the thigh bone (femur). The socket is part of the pelvis called the acetabulum.

In a normal hip, the ball and socket are covered with a smooth layer of tissue called cartilage. The cartilage allows the ball to glide easily inside the socket and provides a cushion to your hip joint. Muscle and ligaments hold your hip joint in place. When the surrounding muscles support your weight and the joint moves smoothly, you can walk without pain.

The Problem Hip

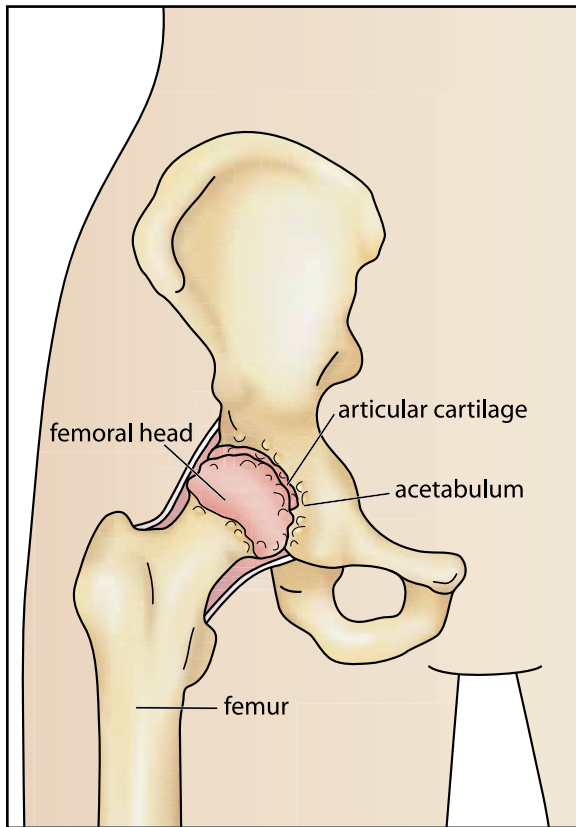

© Allina Health System

Cysts, bone spurs and loss of cartilage can lead to hip problems.

In the problem hip, the worn cartilage no longer serves as a cushion. When cartilage becomes damaged by an injury or by disease, the hip joint cannot move smoothly. As the cartilage wears away from the bones, the bones rub together and become irregular, creating a rough surface. The ball grinds in the socket when you move your leg causing pain and stiffness.

As the pain worsens, you will try not to use the joint as much. This causes the muscles to weaken and the joint to feel unstable and less able to support your body weight. An X-ray can determine the extent of joint damage. A hip joint replacement is an option to relieve the pain and instability.

The Hip After a Hip Replacement



© Allina Health System

An X-ray shows the artificial joint (prosthesis).

The hip replacement surgery removes damaged bone and cartilage from the hip joint and replaces it with an artificial joint (prosthesis). An artificial ball connected to a stem replaces the ball of your thigh bone. An artificial cup, shaped like a bowl, replaces the worn socket. These parts connect to create a new artificial hip that works almost like your own hip joint. All parts have smooth surfaces for comfortable movement once you have healed from the surgery.

Typically the prosthesis is made of a wear-resistant plastic (polyethylene) and a metal (titanium, tantalum or cobalt). The artificial ball and socket are held in place by bone cement, your bone growing into the prosthesis or a combination of both. Your surgeon will determine which prosthesis will work best for you.

There are different approaches for hip replacement surgery, which change as the technology changes. Your surgeon will determine which approach will work best for you, based on your:

- age
- weight
- bone health
- overall health
- activity level
- specific hip degeneration or injury.

The Hip After a Hip Resurfacing



© Allina Health System

An X-ray shows the artificial joint (prosthesis).

Hip resurfacing removes the damaged cartilage from the hip joint. The surgeon replaces the damaged cartilage with an artificial joint (prosthesis).

The artificial joint is made of two polished metal surfaces that rub together with the help of the body's natural joint fluid. The metal surfaces provide a smooth joint for movement.

The upper thigh bone (femur) is capped with a metal prosthesis. A metal cup is placed in the pelvis to replace the worn socket. The pelvic side is placed without cement. The cap on the upper thigh bone (femur) is held in place with bone cement.

Chapter 1: Before Surgery

Your Health History and Physical Exam

Important

Your health history and physical exam needs to be done within 30 days before your surgery.

It is recommended to have the exam done 14 to 30 days before surgery.

Your primary care provider should do a health history and physical exam before your surgery. Call your primary care provider to schedule your appointment.

During the exam, your primary care provider will:

- evaluate your current health status
- review and perform any tests needed before surgery
- make sure you are ready for surgery.

If you take any medicines, make sure your primary care provider gives you instructions for the following:

- taking your medicines the morning of surgery
- stopping any prescription medicines before your surgery
- stopping any over-the-counter medicines before your surgery, including herbal medicines.

Diabetes

Important

Be sure to follow any instructions given to you by your health care provider who manages your diabetes.

If you have diabetes, it is important to have good blood glucose levels before and after surgery. This will help you heal better after surgery and lower your risk of infection.

It is recommended for you to have an A1c level lower than 7.5 percent within 3 months before your surgery. The stress of surgery can sometimes increase your blood glucose level after surgery. You may be given insulin to control your blood glucose while you are in the hospital.

Blood Levels Before Surgery

Did You Know?

Hemoglobin is the most important part of a red blood cell. The protein carries oxygen from your lungs to your tissues. Hemoglobin also takes carbon dioxide from the tissues to the lungs. You breathe out the carbon dioxide when you exhale.

It is important to have normal blood (hemoglobin) levels before your surgery. This will help you handle surgery better and lower your risk of needing a blood transfusion while you are in the hospital.

Talk with your primary care provider about your blood levels before surgery. Your surgery may need to be rescheduled if they are low before surgery. This will give your primary care provider time to find out why they are low and give you any treatments needed to get your blood levels back to normal.

Your blood levels may be low after surgery. This is normal. It may take a few months for your blood levels to go back to normal. You and your health care team will work together to find the best way to make sure your blood levels return to normal after surgery.

Pre-surgery Education Class

Important

Pre-surgery education is an important part of your care. Due to COVID-19, your hospital may not be offering in-person class education.

Visit allinahealth.org/TJR to watch the pre-surgery education class video to learn more about your upcoming surgery.

The hospital at which you are having your surgery may offer a pre-surgery education class. Members of your health care team will be there to answer questions and help guide you through your surgery experience.

It is strongly recommended that you bring a member of your care circle to this class. This person should also be available to act as a “coach” during your hospital stay and recovery.

At the pre-surgery education class, you will learn:

- how to get ready for surgery
- what to expect during your hospital stay
- how to go home safely after surgery.

People who attend the pre-surgery class typically have a smoother recovery and better outcomes after surgery.

Most of the education and tools to help you (and your care circle) prepare for and recover from surgery will be taught during this class. This is also a great opportunity to ask questions!

Scheduling your class

You will need to call to schedule a pre-surgery education class if you are having your surgery at one of the following hospitals:

- Abbott Northwestern Hospital: 612-863-5100
- Buffalo Hospital: Your class will be scheduled for you by your clinic. Call the clinic at 763-684-6160 if you have any questions.
- Cambridge Medical Center: 763-688-6421
- District One Hospital: 507-497-3518
- Mercy Hospital: 763-236-7700
- Mercy Hospital — Unity Campus: 763-236-7700
- Owatonna Hospital: 507-977-2492
- Regina Hospital: 651-404-1002
- River Falls Area Hospital: 715-307-6050
- St. Francis Regional Medical Center: 952-428-2565
- United Hospital: 651-241-5390

Personal Support Coach

Tip

Select your personal support coach **before** your surgery so your coach can make plans to be able to help you as needed after your surgery.

Important

It is recommended to have someone available to help with your care after surgery. The amount of care you will need depends on your recovery. You may only need someone to be available to check on you or you may need someone to help you with all of your activities of daily living.

You are encouraged to select a member of your care circle to be your personal support coach. He or she will support and encourage you to meet milestones during your recovery.

Your personal support coach may also:

- go to the pre-surgery education class with you if offered
- be available during your hospital stay
- go to therapy sessions with you
- be with you as you receive your discharge instructions
- be available to help you in your recovery after you leave the hospital.

Recommended qualities in a coach

C – Caring and compassionate cheerleader

O – Offer comfort and support during your recovery

A – Available to actively participate and help with your rehabilitation

C – Communicate with you and your health care team

H – Help, listen and encourage your return to normal activity

Insurance Coverage

Health care benefits change and differ from plan to plan and provider to provider. It is important for you to understand your health care benefits before your surgery.

Now is a good time to call your insurance provider and find out exactly what is and is not covered under your plan, and how much you have to pay yourself. Use the worksheet on the next page to help you determine your insurance coverage.

Important

If home health care or short-term rehab services are covered by your health insurance, you will still need to qualify for these services.

For example, if you are moving well and are medically stable when you leave the hospital, you may not meet the guidelines for these services. In this case, you may have to pay out-of-pocket for these services if you want them. It is important to have other plans in place in case you do not meet the guidelines.

Determining Your Health Insurance Coverage

Health care benefits change and differ from plan to plan and provider to provider. You are responsible for knowing what your health plan covers. **Call your insurance provider at least 2 weeks before your surgery to learn about your specific coverage.** Look for the phone number on your membership card.

Your surgeon's office will call your insurance provider to determine if pre-approval (prior authorization) is needed and get the pre-approval for you. **Important:** If you change your insurance plan after your first appointment for surgery, let your surgeon's office know right away. A new pre-approval can take up to 3 weeks.

Insurance provider phone number: _____

Policy number: _____

Date/Time of call: _____ Person spoken to: _____

- I am scheduled for total hip surgery at _____ Hospital.
Is this hospital in network? yes no
- Do I have a deductible? yes no If yes, how much is left? \$ _____
How much will my insurance provider pay (co-insurance) after I've met my deductible? \$ _____
Do I have a maximum out-of-pocket amount for the year? yes no
- Will more hospital days be covered if there are problems (complications)? yes no
- If I need medical equipment, am I pre-approved for it? yes no
Do I have to get the medical equipment from a specific source? yes no
If yes, from whom? _____
Do I need a prescription for the equipment? yes no
- If I cannot return to my normal home life right after discharge, do I have benefits for rehabilitation and physical therapy? yes no

Using the table below, review the possible needs and financial concerns with your insurance provider. Ask specific questions to help you get a clear idea of your coverage. Be prepared to share this information with your health care team.

Type	Amount insurance pays	My co-pay	Deductible
Home health care			
Outpatient therapy			
After-surgery medicines			
Medical equipment (chapter 6)			
Transportation* (leaving the hospital)			
Short-term rehab** (if you medically qualify by your insurance provider)			

*Transportation services are usually not covered by insurance companies. Plan ahead and arrange for a member of your care circle to drive you home in a comfortable vehicle after you leave the hospital.

**Short-term rehab is also referred to as transitional care. It takes place in a skilled nursing facility such as a transitional care center or transitional care unit (TCU).

Hospital Pre-registration

After your surgery has been scheduled, you will receive a call from the hospital before your surgery for pre-registration information. Please have the following information ready:

- full legal name and address (including county)
- home phone number
- date of birth
- marital status
- Social Security number
- name of insurance policyholder, his or her address, phone number, work address and work phone number (if insurance is through an employer)
- name of your insurance company, mailing address, policy and group numbers, and copy of insurance card (Note to Medicare beneficiaries: Medicare requires an additional series of questions.)
- name, address and phone number of your employer, and your job title
- name, address and phone number of the nearest relative or spouse if applicable
- name and phone number of someone to call in case of an emergency (can be the same as nearest relative).

Advance Care Planning

How to Get Started

Allina Health offers three ways to help you get started:

1. Sign up for a free advance care planning class. Call 612-262-2224 or 1-855-839-0005 to register.
2. Fill out a free, secure health care directive online. Go to account.allinahealth.org to create an account.
3. Print out a health care directive at allinahealth.org/acp.

Planning for your future health care

Advance care planning is the process of giving information to others about your health care choices in case illness or injury prevents you from telling them yourself.

Talk with members of your care circle about your health care choices. This is a time for you to share:

- what kind of care and treatment you do or do not want
- your wishes, goals and values and how they relate to your health care choices for the future.

You can put your health care choices in writing by creating a health care directive. Members of your care circle and your health care providers will use this document to interpret and understand your wishes, goals and values for your future health care needs.

Medicine Use Before Surgery

Important

Tell your health care team which medicines you took the morning of surgery and what time you took them.

Certain medicines can cause problems (complications) with your surgery unless you stop taking them before surgery.

Talk with your health care provider about **all of the medicines** you take (including prescription medicines such as diabetes medicines, over-the-counter medicines, herbals, vitamins or other supplements) at least 10 days before surgery. Make sure to ask him or her for instructions if you take a combination medicine. Then use the worksheet on the next page to write down medicines you need to continue or stop taking before surgery.



Medicines to keep taking before surgery



If you take any of the medicines on the following list, take your morning dose with a small sip of water before you go to the hospital.

- beta blockers such as atenolol (Tenormin[®]), carvedilol (Coreg[®]) or metoprolol (Lopressor[®])
- any heart medicine such as anti-arrhythmics or calcium channel blockers like diltiazem (Cardizem[®], Dilacor XR[®]), verapamil (Calan[®], Isoptin[®], Verelan[®]) or amlodipine (Norvasc[®])
- asthma medicine (including an inhaler, steroids or both)
- acid reflux medicine
- pain medicine if needed
- seizure medicine

Follow any instructions your health care provider gives you.



Medicines to stop taking before surgery



It is important that you stop taking the following medicines 1 week before surgery or as directed by your health care provider.

- aspirin or medicines that contain aspirin
- blood-thinning medicines such as warfarin (Coumadin[®] or Jantoven[®])
- anti-inflammatories such as ibuprofen (Motrin[®], Advil[®]) or naproxen (Aleve[®])

Follow any instructions your health care provider gives you.



Medicines to Keep Taking



Medicines to Stop Taking

Medicine Name	Medicine Name	When to Stop

Quit Tobacco for Your Surgery

Did You Know?

Tobacco products contain more than 7,000 chemicals. More than 70 are known to cause cancer.

Important

Secondhand smoke causes as much damage to healing as if you were smoking.

If you live with someone who smokes, ask him or her to smoke outside for at least the time of your recovery.

Tobacco and surgery risks

Tobacco products include cigarettes, electronic nicotine delivery systems (ENDS, includes e-cigarettes and JUUL®), smokeless tobacco (dip or chew), cigars, hookahs and pipes.

Using tobacco increases your risk of the following during and after surgery:

- heart problems
- lung problems (complications) such as pneumonia
- infections such as infections of your surgery site (incision)
- blood clots
- slower healing of your surgery site
- higher levels of pain and more problems with pain control.

Tobacco use keeps oxygen from reaching your surgery site and it can increase your recovery time.

Benefits of quitting

- Research shows that quitting 4 weeks before surgery can reduce any problems after surgery up to 30 percent.
- People who quit smoking report having better pain control.
- Your body responds quickly to quitting:
 - **8 hours:** the carbon monoxide level in your blood drops to normal. The oxygen level in your blood increases to normal.
 - **48 hours:** Nerve endings start to grow again.
 - **2 weeks:** Your circulation improves and your lung function increases. (Source: World Health Organization)

When you should quit

Ideally, you should quit as soon as possible. Research shows that:

- the harmful effects from cigarettes begin to go down about 12 hours after your last cigarette smoked
- at least 8 weeks without cigarettes is the best way to reduce problems almost as low as people who do not smoke.

The American College of Surgeons recommends at least 4 weeks without cigarettes.

Did You Know?

Using your surgery as a motivator to quit tobacco increases your success rate of quitting for good.

You should not use tobacco the day of surgery up to 1 week after your surgery. Your doctor may tell you when to quit before your surgery.

If you quit for surgery, you double the chance of staying off cigarettes for good. Many people report they have no cravings while in the hospital.

Not ready to quit? Consider taking a break!

If quitting tobacco makes you feel nervous and seems overwhelming, consider taking a break or a vacation from tobacco use.

- You will get the physical benefits for the period of time that you are not using tobacco.
- You will reduce your risk of problems during surgery and still increase your chances of a smooth recovery after surgery.

If you can, set a goal to stop using tobacco for 1 month after your surgery. This will allow your body to heal the best after your surgery.

Ways to quit or take a break

- abrupt stop (cold turkey)
- nicotine replacement therapy* (gum, lozenge, patch or inhaler)
- medicines (Chantix® and Zyban®)
- behavioral strategies (such as calling a friend or going for a walk)
- aromatherapy (black pepper oil)
- take a break (vacation) from tobacco.

Any step you take without tobacco is going to help you. Small steps are better than nothing!

***Nicotine replacement therapy (NRT) can nearly double your chances of successfully staying off cigarettes. It works best if you use it with the help of a doctor or counselor. Ask your doctor about using NRT around the time of surgery. Go to quitforsurgery.com to learn more.**



***There may be a cost to you.
Check with your insurance provider.**

Resources

Allina Health

- Tobacco Intervention Program at Abbott Northwestern Hospital
— 612-863-1648
- Tobacco Intervention Program at Mercy Hospital
— 763-236-8008
- Tobacco Intervention Program at River Falls Area Hospital
— 715-307-6075
- *United Hospital Lung and Sleep Clinic Tobacco Cessation Program
— 651-726-6200
- *Penny George™ Institute for Health and Healing (LiveWell Center) tobacco intervention coaching
— 612-863-5178

Other

- Quit Partner
— 1-800-QUIT-NOW (1-800-784-8669) or quitpartnermn.com
- Minnesota Department of Health
— health.state.mn.us/quit
- online tobacco cessation support
— smokefree.gov
- American Lung Association/Tobacco Quit Line
— 651-227-8014 or 1-800-586-4872
- Chantix® GetQuit Support plan
— 1-877-CHANTIX (1-877-242-6849) or get-quit.com
- financial aid for Chantix® or Nicotrol® inhaler
— 1-866-706-2400 or pfizerrxpathways.com
- *Mayo Clinic Nicotine Dependence Center's Residential Treatment Program
— 1-800-344-5984 or 1-507-266-1930
- Plant Extracts aromatherapy
— 1-877-999-4236



Chapter 2: Preparing for Surgery

Before Surgery Exercise Program

Important

- Visit allinahealth.org/pt to watch a video on pre-surgery therapy and common activity precautions you can expect after hip replacement surgery.
- Visit ckri-allina.medbridgego.com/access_token/TQMW3DD2 to watch videos on your hip exercises before surgery. Click on “verify access code” to watch the videos.

You may have discovered you have been less active because of your hip joint discomfort. When muscles are not used, they become weak and do not perform well in supporting and moving your body.

Having your hip surgery will correct the joint problem, but you will need a regular exercise program to strengthen and stretch your muscles to properly support your new joint.

Beginning an exercise program before surgery can greatly help your recovery.

The following pages list several exercises for you to work on before your surgery. Because everyone responds to exercise differently, you need to be the judge of how much exercise you can do each day. **If an exercise causes an increase in discomfort, stop doing that exercise.**

You should try to exercise 1 to 2 times a day, every day, before surgery. Work up to doing 10 to 20 repetitions of each exercise. It may be helpful to do these exercises on both legs.

For the most comfort, do the exercises lying down. Your bed is an excellent place to do your exercises.

Walking

Tip

See chapter 5 for information about starting a walking program.

Important

Do not walk if it causes pain or swelling.

Walking before surgery can help you have a successful recovery. Regular walking can also help to:

- prevent constipation
- make you feel better
- manage your weight
- improve muscle tone
- keep your joints flexible
- improve healing by promoting blood flow (circulation)
- promote sleep.

It may be helpful to set a time of day such as morning or evening to add a walk.

Hip exercises — before surgery

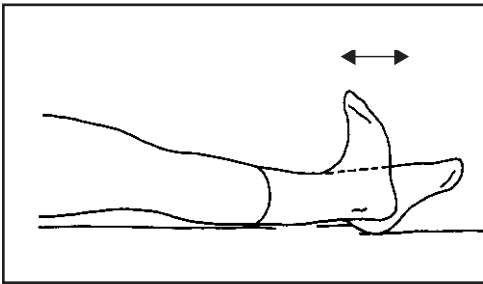

Ankle pumps

Pump your feet up and down by pulling your feet up toward you, then pushing your feet down away from you.

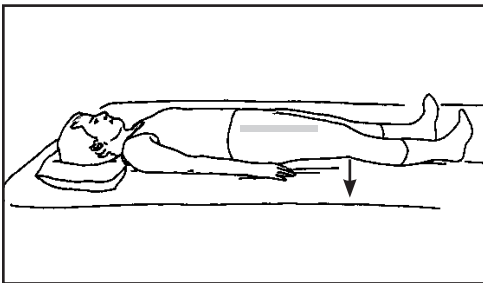

Thigh squeezes (quadriceps sets)

Tighten the muscles on the top of your thigh by pushing the back of your knee down into the bed. **Hold for 5 seconds and relax.**

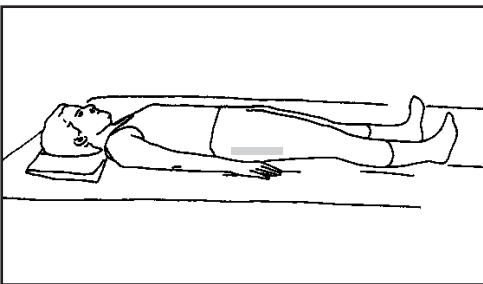

Buttocks squeezes (gluteal sets)

Tighten your buttocks muscles by squeezing the muscles together. **Hold for 5 seconds and relax.**

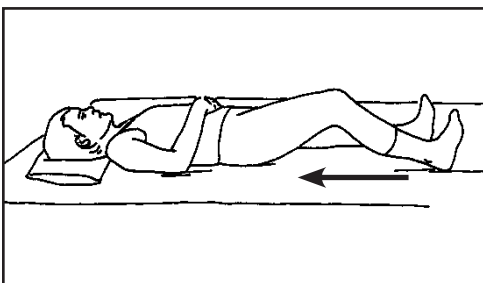

Heel slides (hip and knee flexion)

Bend your surgical hip and knee by sliding your heel up toward your buttocks while keeping your heel on the bed. Slide your heel back down to the starting position and relax. Keep your kneecap pointed up toward the ceiling during the exercise. You may want to use a plastic bag under your heel to help it slide easier.

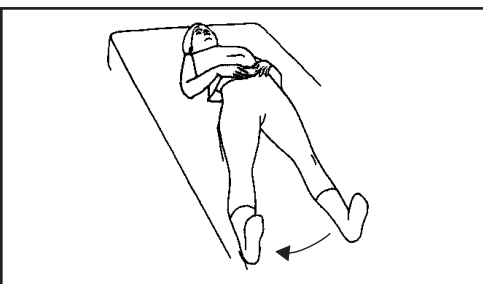

Leg slides (abduction/adduction)

Slide your surgical leg out to the side, keeping your kneecap pointed up toward the ceiling. Slide your leg back to the starting position. You may want to use a plastic bag under your heel to help it slide easier.

Drawings © Allina Health System

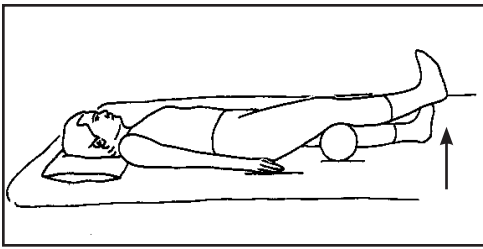

❑ Lying kicks (short arc quadriceps)

Lie on your back with a rolled-up blanket or towel (at least 6 inches in diameter) under the knee of your surgical leg. Straighten your surgical leg. **Hold for 5 seconds.** Slowly lower your leg down and relax. The back of your knee should stay in contact with the blanket or towel during the exercise.

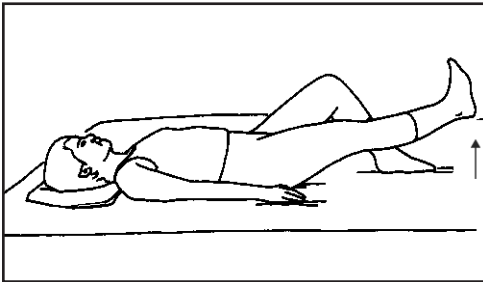

❑ Straight leg raises

Bend your other leg with your foot flat on the bed. Raise your surgical leg up (about 12 inches), keeping your knee straight. **Work up to holding for 5 seconds.** Slowly lower your leg down and relax. If you are unable to do this exercise lying down, you can also do it standing up. (See standing exercises on page 86.)

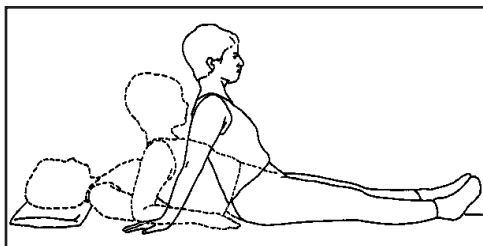

❑ Bed mobility exercise

Lie flat on your back. Come up on both elbows. Straighten your arms out behind you and come to a sitting position. Lower yourself down onto your elbows again, then down to lying flat.

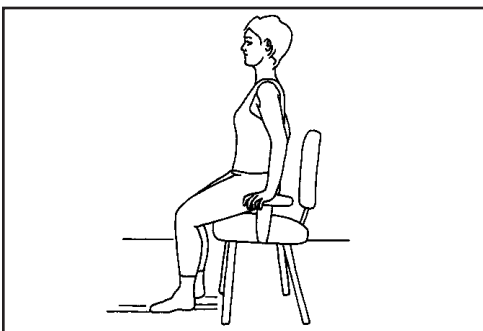

❑ Chair pushups

Sit on a sturdy chair with arms. Hold the arms of the chair. Push down on the chair arms, straightening your elbows so you raise your buttocks a few inches off the seat of the chair. **Work up to holding for 5 seconds.** Lower yourself slowly back into the chair. If your arms are weak, use your legs to help raise your buttocks off the seat of the chair.

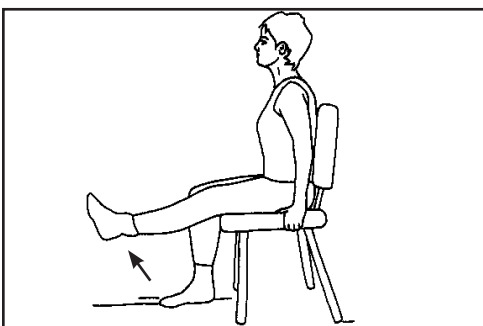

❑ Sitting kicks (long arc quads)

Sit on a sturdy chair. Straighten your knee. **Hold for 5 seconds.** Slowly lower your leg down and relax.

Drawings © Allina Health System

Before surgery exercise program — hip surgery

Check the box under the appropriate day and week after you perform the exercises selected for you.

Exercise	Week 1							Week 2							Week 3							Week 4						
	M	T	W	Th	F	S	S	M	T	W	Th	F	S	S	M	T	W	Th	F	S	S	M	T	W	Th	F	S	S
Ankle pumps																												
Thigh squeezes																												
Buttocks squeezes																												
Heel slides																												
Leg slides																												
Lying kicks																												
Straight leg raises																												
Bed mobility exercise																												
Chair pushups																												
Sitting Kicks																												

Mobility and Activity Techniques for Daily Living

Tip

Do not use a walker to pull yourself up from a sitting position. This could cause you to fall.

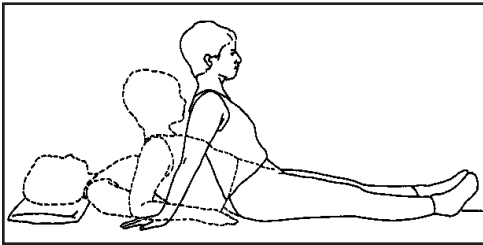

Follow the instructions to the right for how to get in and out of bed.

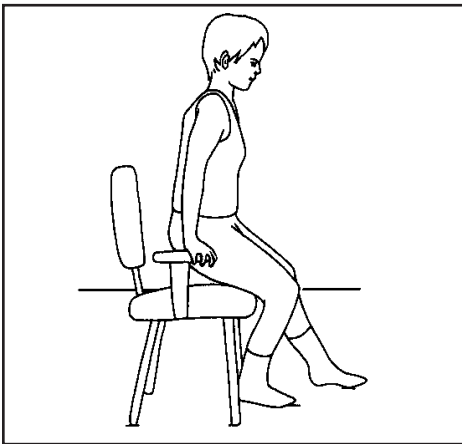

Drawings © Allina Health System

Follow the instructions to the right for how to get in and out of a chair with arms.

After hip surgery, you may need to move differently until your hip heals. Use the following instructions to help you move throughout your day.

Getting in and out of bed

- Back up until you feel the bed against the back of your legs.
- Place your surgical leg forward.
- Reach back for the bed surface, lowering yourself slowly to the edge.
- Scoot back on the bed in a diagonal direction until your knees feel supported.
- As you turn your body to get into bed, you may need to use a leg lifter or someone to help lift your surgical leg.
- When getting out of bed, come to a sitting position on the bed.
- As you turn your body to get out of bed, you may need to use a leg lifter or someone to help move your surgical leg.
- Lean back as you push with your hands to help move your body forward until you are sitting at the edge of the bed.
- Place your surgical leg forward.
- Push up from the bed and stand up.
- Do not reach for a walking device until your balance is secure.

Getting on and off a chair with arms

- To sit down, back up until you feel the chair against the back of your legs.
- Place your surgical leg forward.
- Reach back for the arms of the chair with both hands and sit down on the edge of the seat, then slide back.
- To get off the chair, slide to its edge.
- Place your surgical leg forward.
- Push up with both arms and your nonsurgical leg.
- Do not reach for a walking device until your balance is secure.

Getting on and off a toilet

- To get on and off a toilet, follow the steps above for getting on and off a chair.
- Using a raised toilet seat may make it easier and safer for you to get on and off the toilet.
- When sitting or standing, support yourself with grab bars or nearby structures (sink, counter) that are secure.

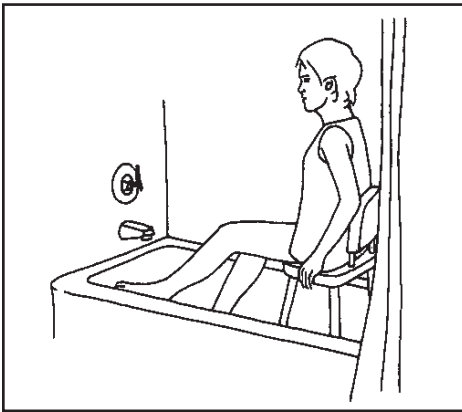

Use a shower chair to help you take a shower safely.

Getting in and out of the tub to take a shower

Have someone nearby the first few times you use the tub or shower to provide balance assistance if needed. It is a good idea to have hand rails or grab bars to help with your balance and support. There are two ways you can get in and out of the tub to take a shower.

Side-step transfer:

- Side-step into the tub with your nonsurgical (“good”) leg first. Hold the walker, wall or grab bar for support. Next, bring your surgical (“bad”) leg over the tub edge.
- Side-step out of the tub with your surgical leg first. Hold the walker, wall or grab bar for support. Next, bring your non-surgical leg over the tub edge.

Seated transfer:

- Using a shower chair with a backrest may make it easier to get in and out of the tub.
 - Getting into the tub:
 - Reach back for the chair, sit down, scoot back and carefully swing each leg (one at a time) over the tub edge.
 - Getting out of the tub:
 - Swing each leg (one at a time) over the tub edge. Scoot forward on the bench with your feet flat on the floor and push up from the shower chair to stand.
 - Do not reach for a walking device until your balance is secure.

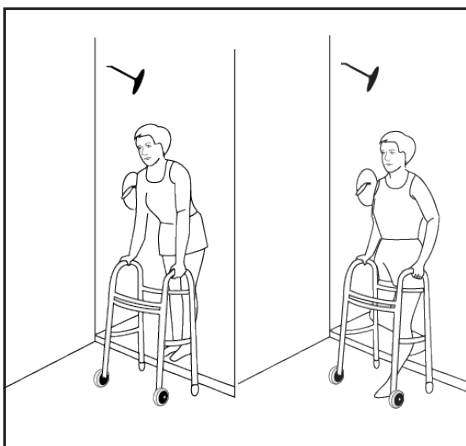

Drawings © Allina Health System

Follow the instructions to the right for how to get in and out of a walk-in shower.

Getting in and out of a walk-in shower

There are two ways you can get in and out of the shower.

Back in technique:

- Approach the shower and then turn around backward to enter.
- Leave your walker outside of the shower.
- To provide balance and help you maintain your activity restrictions, it is important to have someone help you. The following items may also be helpful to keep you safe:
 - a grab bar
 - a shower chair
 - a nonskid mat.

Side-step technique:

- Getting into the shower:
 - Step into the shower with your nonsurgical leg first.
 - Then step into the shower with your surgical leg.
 - If a shower chair is available, reach for the seat and slowly lower yourself into a sitting position.
- Getting out of the shower:
 - If using a shower chair, push up from the seat and slowly stand.
 - Step out of the shower with your surgical leg first.
 - Then step out of the shower with your nonsurgical leg.

Reaching, bending, carrying

- Use a reliable support like the countertop or table when bending and reaching in low cupboards.
- A reacher can help reduce strain on your hip and make it easier to pick objects up from the floor.
- Do not carry or hold anything in your hands while using a walker or crutches. Use pockets in an apron, walker basket, fanny pack or backpack.
- Do not reach too far when you slide objects across a countertop.
- Try using a rolling cart to move heavy, hot or breakable items.

How to go up and down stairs

Your physical therapist will review stair climbing with you in the hospital.

- Remember to go up the step with your nonsurgical leg first, then bring your surgical leg up to the same step. “Up with the good.”
- Also remember to go down the step with your surgical leg first, then bring your nonsurgical leg down to the same step. “Down with the bad.”

Follow the instructions to the right for how to get in and out of a car.



Step one

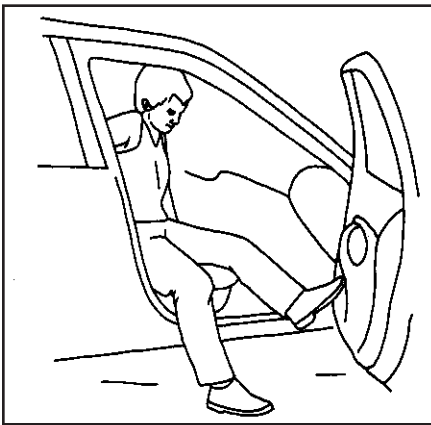

Step two

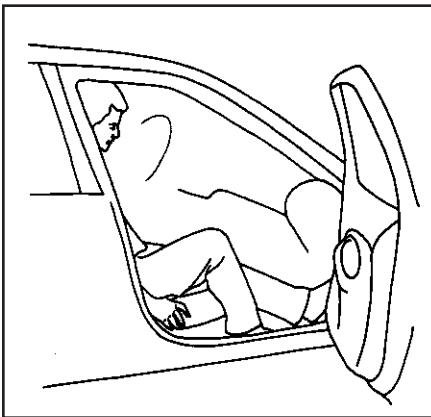

Drawings © Allina Health System

Step three

Getting in and out of a car

A large plastic bag on the car seat may help you move more easily. Also, a firm pillow under your buttocks may be needed to increase the seat height so your hips are higher than your knees.

Any time you are getting in or out of the car, have the driver park about 4 feet out from the curb edge and not on an incline. Also make sure the surface you will be walking on is free of ice and snow.

Before surgery, practice getting in and out of a car using the following instructions.

- Adjust the car seat as far back as possible and recline the backrest slightly.
- Back up to your car seat. Place your surgical leg forward.
- Reach back and find a stable hand hold (dashboard, back of the seat).
- Slowly lower yourself onto the seat.
- Scoot back before lifting each leg into the car.
- Do not reach for your walking device until your balance is secure.

Breathing Exercises (Respiratory Exercises)

Tip

An incentive spirometer is a hand-held breathing exercise device to help you inflate your lungs after surgery. This will help keep your lungs healthy after surgery.

You can read about how to use an incentive spirometer in chapter 3.

Performing respiratory exercises will help you prevent respiratory system complications. Deep breathing, coughing, and incentive spirometer exercises may speed your recovery and lower your risk of lung problems such as pneumonia. Learn the following exercises and practice them every day before your surgery.

Deep breathing

To deep breathe correctly, you must use your abdominal muscles, as well as your chest muscles.

- Breathe in through your nose as deeply as possible.
- Hold your breath for 5 to 10 seconds.
- Let your breath out through your mouth, slowly and completely. As you breathe with pursed lips (like blowing out a candle), your stomach should be going in. Exhale twice as long as you inhale.
- Rest and then repeat these steps with 10 repetitions.

Coughing

To help you cough:

- Take a slow deep breath. Breathe in through your nose and concentrate on fully expanding your chest.
- Breathe out through your mouth and concentrate on feeling your chest sink downward and inward.
- Take a second breath in the same manner.
- Take a third breath. This time hold your breath for a moment, then cough vigorously. As you cough, concentrate on forcing all the air out of your chest.
- Repeat this exercise two more times.

Preparing Your Home for Your Needs After Surgery

Use the following guidelines to help prepare your home for your recovery. Check each item box as you complete that item.

Outside your home

- Check stair railings to make sure they are secure. If you are adding a railing, extend it a few inches past the end of the staircase. It is best if all stairs have railings.
- Be aware of uneven ground around your home and in your yard.
- Be sure your driveway and walking paths are uncluttered.
- Find someone to do your yard work.

Inside your home

- Have clear pathways and remove clutter around your home.
- Make a walking path that a walking aid such as a walker will fit through your home.
- Pick up all throw rugs in your walking or standing path. Consider using double-face tape to secure carpet edges.
- Check stair railings to make sure they are secure. If you are adding a railing, extend it a few inches past the end of the staircase. It is best if all stairs have railings.
- If you have low furniture, you can increase the chair height with an extra cushion or furniture risers.
- Consider first floor options (temporary) if your bathroom is not on the main floor. Do you have access to a portable commode?
- Make your phone accessible to your main sitting area and bed. Cordless phones or cell phones are helpful. Carry a cordless phone or cell phone when you are home alone in case of an emergency.
- Do not carry or hold anything in your hands while using a walker or crutches. Use pockets in an apron, walker basket, fanny pack or backpack.
- Depending on your driveway and how well you are able to move, you may consider arranging to have your paper and mail delivered to your door rather than curbside as needed.
- Arrange transportation to the grocery store, community events, family activities, and doctor and therapy appointments.
- Find someone to help care for your pet if needed.

Tip

See chapter 6 for more information on medical equipment you may need after your surgery.

Kitchen

- Ask someone to help you move heavy or hot items.
You can also use a kitchen cart.
- Prepare and freeze a few meals before your surgery.

Bedroom

- Place a lamp close to the bed where it is easy to reach.
- Plug in a night light. Some night lights turn on by themselves after dark.

Bathroom

- You may need a raised toilet seat or toilet safety frame.
- Consider putting grab bars in the bathtub, shower or both.
Also consider other key areas for grab bars such as by the toilet.
(Grab bars should be installed into wall studs to ensure they are secure.)
- Have access to a shower, tub transfer bench or both for showering.
- Apply adhesive slip strips or a bath mat to the tub or shower floor.
- Consider a hand-held shower head.

What to Bring for Your Hospital Stay

Important

Please do not bring any of the following:

- valuables
- medicines (pills, inhalers)
- large amounts of money
- jewelry (wedding ring).

Allina Health will not be responsible for lost or stolen items.

Reminder

Please have a member of your care circle bring your belongings into the hospital after your surgery is done and you have been assigned a room number.

Please bring the following to the hospital.

- this education book
- a current list of your medicines (The “My Medicine List” is on page 97 for you to fill out.)
- a copy of your health care directive (if you have one)
- driver’s license or photo ID
- your insurance information (insurance card, Medicare card, work compensation information or all three)
- personal care items such as a toothbrush, toothpaste, denture cleaner, comb, skin care products, deodorant, make-up and shaving kit
- loose-fitting tops and bottoms (shorts with an elastic waistband, generous sweat pants). You will get dressed each morning in your own clothes.
- clothing you will wear home, including loose-fitting pants, shirt, underwear and socks
- flat shoes or athletic shoes (comfortable, supportive with nonslip soles)
- glasses or contacts (if you wear them) and storage containers
- hearing aids (if you wear them), storage container and extra batteries
- CPAP machine (if you use one)
- reading materials (All rooms have a television and phone.)
- phone numbers of family and friends
- cell phone charger
- rolling walker with front wheels (if you have one).
Your physical therapist can make adjustments to your walker for you. (Be sure to label it with your name.) If you do not have an assistive walking device, your physical therapist will help you get the medical equipment you need while in the hospital.
- money to buy equipment to take home if needed. It’s a good idea to ask a member of your care circle to bring this to you. Allina Health will not be responsible for lost or stolen items.

Preparing Your Mind and Body for Surgery

Studies have shown that if your mind and body are ready for surgery you may sleep better and have less anxiety and pain. Your hospital stay may also be shorter.

The Penny George™ Institute for Health and Healing

The Penny George™ Institute for Health and Healing offers services to help you as you prepare for and recover from surgery. Call 612-863-3333 or visit allinahealth.org/pennygeorge for more information, or ask your health care team which services are offered at your hospital.

Preparing for Surgery

Did You Know?

You can talk with your surgeon about if getting a temporary handicap parking form is right for you.

You will receive information with the date and time of your surgery and the time you need to arrive at the hospital.

You will be asked to come to the hospital at least 2 hours before your scheduled surgery. This will give the health care team enough time to prepare you for surgery.

It is important to arrive on time. Your time of surgery could start earlier than expected. If you are late, your surgery may be delayed or it may need to be canceled and scheduled at a later date. Please call your surgeon's office if you have any questions.

The Day Before Surgery

- Tell your surgeon if you have any changes in your health (sore throat, cold, fever, dental problem, urinating problem) or skin condition (rash, abrasions). You may need to schedule your surgery for a later date.
- Take your regular medicines (heart, blood pressure, diabetes or pain medicine) as directed by your primary care provider with a small sip of water. Your primary care provider will tell you if he or she does not want you to take any or all of your regular medicines.
- Bathe or shower using the "Cleansing Your Skin for Your Surgery" instructions on the next pages or as directed by your surgeon.

Cleansing Your Skin for Surgery

Tip

If you cannot wash the surgery area yourself, have a member of your care circle help you.

Before surgery, you have an important role in reducing your risk of infection at the surgery site. You can reduce the number of germs on your skin by gently cleansing your skin with the Sage® 2% Chlorhexidine Gluconate Cloths. **Do not use these cloths if you have an allergy to chlorhexidine gluconate.**

Important: Do not shave your body below your neck 7 days before your surgery.

The night before surgery, take a bath or shower. Wait 1 to 2 hours. Wipe your skin well with the Sage cloths. They have a special antiseptic solution. Use both of the cloths in each of the three packages. **Please do not follow the instructions on the Sage packages when cleansing your skin. Follow the instructions below.**

Night before surgery (at least 1 to 2 hours after taking a bath or shower)

- Gather your supplies: three packages of Sage 2% Chlorhexidine Gluconate Cloths, scissors, and clean clothes or sleepwear.
- Open all three packages. Remove the cellophane wrappers and throw them away. Use scissors to cut open the packages. Cut straight across the top of each package.
- Reach into one of the three open packages. Take out two cloths at one time with the foam holder and put them on a clean surface. Repeat for the second and third packages.
- **After you start using the cloths, do not touch your eyes, ears or mouth.**
- Follow the skin cleansing steps on the next page.
 - Gently cleanse your skin using a back-and-forth motion.
 - Be sure to completely cover each area. You may need help wiping some areas of your body.

Tip

Cleanse your skin gently with the cloths.

After you gently cleanse each area, let your skin air dry for 1 to 3 minutes. It is normal for your skin to feel tacky or sticky for several minutes after you apply the solution.

- **Do not rinse or rub off the solution.**
- **Do not apply deodorant, perfume, lotions, moisturizers, gels, powders or make-up after cleansing your skin.**
- Throw away the used cloths. Do not flush them down the toilet.
- Wash your hands with warm water and soap.
- Put on clean clothes or sleepwear.
- Put clean sheets on your bed. Make sure pets stay off of your bed to keep it clean.

Chlorhexidine wipes warning

Do not use chlorhexidine wipes or liquid if you:

- are sensitive to surgery skin preps
- know you have an allergy to chlorhexidine.

If you notice your skin is irritated while using the chlorhexidine wipes or liquid, remove it gently with a wet washcloth. Tell your pre-surgery nurse you had a reaction so he or she can make a note of your allergy history and tell others on your health care team.

There are rare cases of this product causing a serious allergic reaction. This can occur within minutes of use. **Call 911 if you have any of these:**

- wheezing or trouble breathing
- swelling of the face
- hives
- severe rash
- shock.

Skin cleansing steps

- ① Using the first cloth, **wipe your neck and chest.**
- ② Using the second cloth, **wipe both arms.** Start at your shoulder and end at the fingertips. Be sure to wipe well under each arm and in the armpit areas.
- ③ Using the third cloth, **wipe your right and left hip, then your groin.** Be sure to wipe any folds in the stomach and groin areas.
- ④ Using the fourth cloth, **wipe both legs.** Start at the thigh and end at the toes. Be sure to wipe the front and back of each leg.
- ⑤ Using the fifth cloth, **wipe your back.** Start at the base of your neck and end at the buttocks.
- ⑥ Using the sixth (last) cloth, **rewipe the surgery area.**

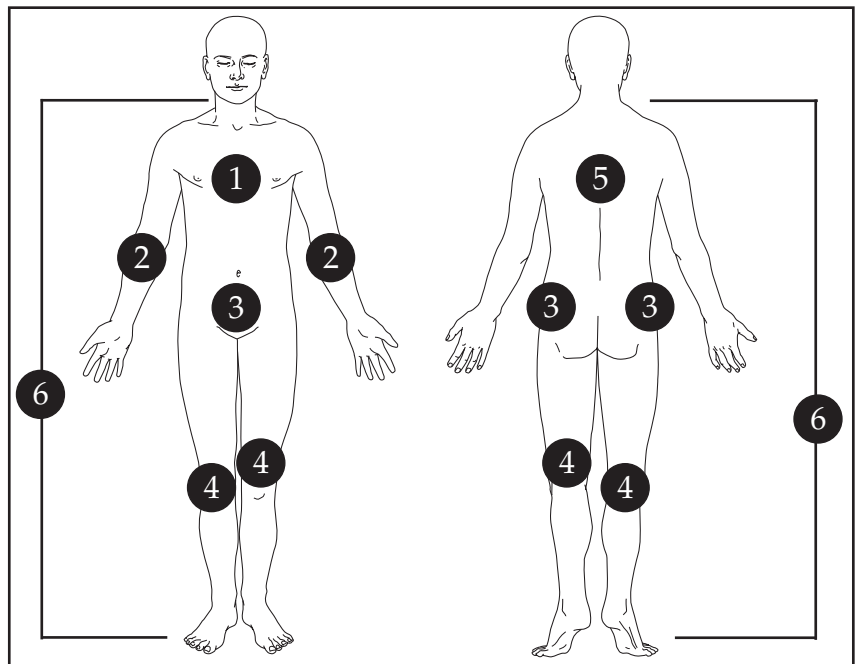

© Allina Health System

The numbered areas in the drawing show where to cleanse your body using each of the cleansing cloths. The numbers in the text above give you more details on how to cleanse your body.

Food and Liquid Directions Before Your Surgery

These directions are based on your scheduled arrival time. Not following these directions could mean your surgery will be delayed or canceled.

Alcohol and tobacco: 24 hours

- Do not drink any alcohol 24 hours before your scheduled arrival time.
- Do not smoke, vape, use chewing tobacco or use any other tobacco products up to 24 hours before your scheduled arrival time.

Solid foods: 8 hours

- Eat up to 8 hours before your scheduled arrival time.
 - Eat light meals such as oatmeal or toast.
 - Do not eat foods that are heavy or high in fat such as meat or fried foods.

Clear liquids: 2 hours

- Drink only clear liquids up to 2 hours before your scheduled arrival time.
 - Drink water, fruit juice without pulp, black coffee, clear pop or tea.
 - Do not have milk, yogurt or energy drinks.

Medicines

- Take your medicines as directed with a small sip of water.

The Morning of Surgery

Important

Do not take a bath or shower the morning of your surgery.

- If you were given instructions by your health care provider to take medicines the morning of your surgery, take them as directed with a small sip of water.
- Put on clean, comfortable clothes to wear to the hospital.
- Arrive at the hospital at least 2 hours before your surgery. Allow extra time for walking, bad weather and traffic.

Chapter 3: Surgery, Hospital Stay and Beyond

What to Consider About Visitors

Your health care team will balance this activity with rest periods. Support from your care circle is also essential to your recovery and should be balanced with your rest needs.

What to Expect the Day of Surgery

Important

Tell your health care team which medicines you took the morning of surgery and what time you took them.

When you arrive at the hospital

- Go to the surgery registration area.
- After you check in, you will be directed to the pre-surgery care area.

Pre-surgery care area

- Go to the waiting room.
- You will be brought back to a pre-surgery care suite.
- A nurse will meet with you to complete your care plan.
- After you are settled, the person with you on the day of surgery will be invited back to join you.
- Your nurse will review what you can expect before and after your surgery.
- Your anesthesiologist (doctor) will also meet with you. Your anesthesiologist and surgeon will work with you to choose the right type of anesthesia for your surgery.
- Your surgeon will also visit with you. He or she will mark the surgery site on your body and answer any questions you may have.
- You will be asked to sign a consent form.

Information for your care circle

- While you are in surgery and recovery, your care circle can wait in the surgery waiting room.
- Your surgery time will vary depending on the condition of your hip. Your surgeon will talk with your care circle when your surgery is over.

Anesthesia: What You Need to Know

Important

On the day of your surgery, your anesthesia care team will determine the best type of anesthesia for you.

Anesthesia is a combination of medicines that block the feelings of pain sensation and minimize awareness during surgery. You will receive other pain medicine to give you pain relief during and after surgery.

Before surgery you will meet your anesthesia care team, an anesthesiologist or a certified registered nurse anesthetist (CRNA). They will review your medical history and talk with you about your anesthesia options. Your anesthesia care team will come up with a plan to best take care of you.

Post Anesthesia Care Unit (PACU)

- After surgery, you will be taken to the recovery room or Post Anesthesia Care Unit (PACU).
- Most people stay about 1 to 1 ½ hours here. Your time in the PACU will depend on your surgery and how fast you recover from the anesthesia.
- Your nurse will monitor your vital signs and help you if you have any side effects from the anesthesia.
- You may have some discomfort and pain when you wake up. Everyone reacts to pain differently. Your nurse will work with you to make you as comfortable as possible.
- An X-ray may be taken of your new joint in the PACU.

Post-surgery unit

- When you are fully awake and your medical status is stable, you will be taken to your room in the post-surgery unit where nurses specialized in joint replacement will care for you.
- When you are in your room, it is important to begin:
 - doing ankle pump exercises. This will help to prevent blood clots from forming in your legs.
 - using your incentive spirometer and doing the deep breathing exercises. See page 56 for instructions for how to use your incentive spirometer.

Pain After Surgery

You will have pain after surgery. Together, you and your health care team will create a pain plan that is right for you.

You and your health care team will also establish a “pain goal” – the amount of acceptable pain you can handle. Your health care team will help you balance your pain so you are able to do your physical therapy and activities of daily living.

Pain scale

Using a number scale (0 to 10) to rate your pain will help the health care team members know how severe your pain is and help them make decisions about how to treat it.

Your Pain Goal

(number)

I want to be able to:

Allina Health Pain Assessment Scale

10	Worst Pain You Can Imagine
7-9	<p style="text-align: center;">Severe Pain</p> <p style="text-align: center;">Pain keeps you from doing your regular activities.</p> <ul style="list-style-type: none"> ⑨ Pain is so bad that you can't do any of your regular activities, including talking or sleeping. ⑧ Pain is so intense that you have trouble talking. ⑦ Pain distracts you and limits your ability to sleep.
4-6	<p style="text-align: center;">Moderate Pain</p> <p style="text-align: center;">Pain may interfere with your regular activities.</p> <ul style="list-style-type: none"> ⑥ Pain makes it hard to concentrate. ⑤ You can't ignore the pain but you can still work through some activities. ④ You can ignore the pain at times.
1-3	<p style="text-align: center;">Mild Pain</p> <p style="text-align: center;">Pain doesn't interfere with your regular activities.</p> <ul style="list-style-type: none"> ③ You may notice the pain but you can tolerate it. ② You may feel some twinges of pain. ① You may barely notice the pain.
0	No Pain

Adapted with permission by Dr. Armaan Singh, 2015.

Your role in creating a pain plan

After surgery, it is common to have pain. A member of your health care team will monitor your pain level often and help you review treatment options.

All of the following information will help your health care team prescribe the right medicine and therapy for your pain, and prevent problems (complications). Tell a member of your health care team:

- if you have allergies or reactions to pain medicine(s)
- what methods of pain control have worked or have not worked well in the past
- where you feel pain and how much pain you have (Use words to describe how the pain feels.)
- what makes your pain better or worse
- if your pain starts to get worse or you have new pain
- what vitamins, herbal and natural products you are taking
- if you drink more than two alcoholic drinks each day.

Treatments for pain

If you have short-term or sudden pain from surgery, injury or illness, opioid pain medicine may help you to have less pain. Opioid pain medicine is one strategy out of many that you may use to have less pain and a speedier recovery.

The goal of opioid pain medicine is to reduce pain when it is most intense during your recovery. It is important to switch to non-opioid pain medicines as soon as you are able.

How to relieve pain or discomfort without medicine

Medicines are a great way to relieve pain. However, sometimes they don't last long enough or cause too many side effects.

Your nurse can give you many ways to relieve pain or discomfort that don't involve medicine. Please ask your nurse for more information about any of the following treatments.

Aromatherapy

Aromatherapy uses essential oils to encourage your body's natural ability to relax and heal. Studies have shown that using aromatherapy helps reduce pain, anxiety, upset stomach (nausea) and being unable to sleep (insomnia).

Activity

Spending too much time lying down or sitting in one position can cause pain, muscle cramps or fatigue. Going for a walk can help reduce discomfort and upset stomach. By being active, you shorten your recovery time and you lower your risk for pneumonia, blood clots and constipation.

Back rub or massage

Massage helps to reduce pain, anxiety, muscle tension and stress.

Effleurage (gentle massage)

Effleurage is a type of gentle massage that involves little to no pressure. It uses gentle strokes on your skin to relax your muscles and helps get your blood flowing. It is good if you don't like or don't want a regular massage.

Important

Follow your surgeon's instructions on when it is OK to take a shower.

Shower

Standing under a hot shower can reduce pain, ease sore muscles and help you relax.

Breathing and relaxation

Your nurse can show you some easy breathing exercises that can reduce pain. This helps lower your heart rate and blood pressure and increase blood flow to your muscles. Relaxation techniques are shown to increase mood and reduce feelings of stress.

Changes to your environment

Simple things like dimming the lights, lowering the curtains, turning off the TV, closing the door or adjusting the temperature in your room can help you rest and relax. These changes can also help if you have headaches or migraines.

Relieving Pain without Medicine

Your surgeon may want you to try other options not listed here.

Ice or cold pack

Cold reduces discomfort and swelling (inflammation) by numbing nerve endings. It is great to help ease pain after surgery. It can also be used for back pain, arthritis and headaches. Use ice or a cold pack for 15 to 20 minutes at one time.

Talk with your nurse about how often you can use ice to help prevent skin damage.

Change positions in bed

You may not be able to get out of bed. Changing the position of your body in the bed often — every 2 hours — can reduce pain and discomfort. Making sure your hips, back and head are in proper alignment can be a great way to prevent muscle strains, joint or back pain.

A member of your health care team will help you change positions.

Rest

Activity and moving is important for your recovery. However, you may do more activity than your body can tolerate. Allowing your body to rest is also important when recovering from a surgery.

Pace your activities and movement with rest. As you recover, slowly do more activities.

Medicines That May Be Used During Your Recovery After Surgery

Along with pain medicine, some of the following medicines may be used while you are in the hospital. Your health care team will give you instructions for any medicines you need to take after you leave the hospital. **Always follow any instructions given to you from your health care team to help prevent complications. Do not take any new medicines without first talking to your surgeon.**

Type of Medicine and Examples	Purpose	Possible Side Effects	Preventing Side Effects
Stool softeners <input type="checkbox"/> MiraLAX® <input type="checkbox"/> senna (Senokot®) <input type="checkbox"/> magnesium hydroxide (milk of magnesia) <input type="checkbox"/> bisacodyl (Dulcolax®)	Help to prevent constipation	<ul style="list-style-type: none">■ diarrhea■ nausea■ stomach cramps■ dizziness	<ul style="list-style-type: none">■ Drink plenty of liquids.
Anti-inflammatory pain medicine <input type="checkbox"/> ketorolac (Toradol®) <input type="checkbox"/> celecoxib (Celebrex®) <input type="checkbox"/> ibuprofen (Advil®, Motrin®)	Decrease swelling at the surgery site	<ul style="list-style-type: none">■ nausea■ gas■ dizziness■ drowsiness■ headache	<ul style="list-style-type: none">■ Do not take on an empty stomach.

Type of Medicine and Examples	Purpose	Possible Side Effects	Preventing Side Effects
Antibiotics <input type="checkbox"/> cefazolin (Ancef [®] , Kefzol [®]) <input type="checkbox"/> vancomycin (Vancocin [®])	Help to prevent infection at the surgery site	<ul style="list-style-type: none"> ■ diarrhea ■ itching 	<ul style="list-style-type: none"> ■ Take for only a short time after surgery. Follow any instructions given to you.
Anti-nausea <input type="checkbox"/> ondansetron (Zofran [®]) <input type="checkbox"/> prochlorperazine (Compazine [®])	Help to decrease nausea	<ul style="list-style-type: none"> ■ dry mouth ■ blurred vision ■ constipation ■ dizziness ■ lightheadedness ■ headache 	<ul style="list-style-type: none"> ■ Do not take on an empty stomach.
Blood thinning medicines (anti-coagulation) <input type="checkbox"/> aspirin <input type="checkbox"/> enoxaparin (Lovenox [®]) <input type="checkbox"/> rivaroxaban (Xarelto [®])	Help to prevent blood clots	<ul style="list-style-type: none"> ■ bruising ■ nausea ■ heart burn ■ skin rash 	<ul style="list-style-type: none"> ■ Take for only a short time after surgery. Follow any instructions given to you. ■ Do not do activities that may lead to injury.

What to Expect During Your Hospital Stay

Important

Make sure you know the answers to the following questions before discharge.

- How do I care for my incision?
- What follow-up appointments do I need?
- Do I have activity restrictions?
- Do I understand my new medicines?
- Do I have my discharge medicines or know where to pick them up?

Please ask your driver to be at the hospital the day of discharge at the time your nurse shared with you.

- Your health care team will help you start moving soon after your surgery. This may include:
 - standing next to your bed
 - walking in your room
 - sitting in the recliner chair
 - walking around the post-surgery unit.
- You can expect to be dressed in your loose-fitting clothing.
- The physical therapist will assess your progress and help you walk with a walker. The occupational therapist may also meet with you to help you practice getting dressed, bathing and using the toilet.
- It is strongly suggested that your coach participates in therapy sessions. Ask your health care team about the current visitor guidelines and when it is best for you to have visitors.
- The amount of time you will be in the hospital will depend on how quickly you recover. You will leave the hospital (discharge) when you meet your therapy goals and you are medically stable. This includes:
 - your pain is managed with pain medicine (by mouth)
 - being able to pass urine without problems (or having a plan for this)
 - being able to eat your regular foods
 - being able or having a plan for activities of daily living (getting dressed, bathing)
 - moving safely with an assistive walking device
 - understanding how to do your exercises
 - being able to go up and down stairs, if needed.

Remember, each person's recovery will be different. Your health care team will help guide you through your recovery and help determine a safe discharge plan.

Preventing Problems (Complications)

Tip

Ask a member of your health care team if you have any questions about the activities to help prevent problems.

Your health care team will do many things to reduce your chance of developing a complication after surgery.

- Your blood pressure, temperature and pulse will be taken often after surgery.
- Your surgical leg will be checked often for movement, feeling, circulation and pulse.
- You will do thigh squeezes, buttock squeezes and ankle pumps to improve circulation and strength.
- You will receive medicine to prevent blood clots.
- You will do deep breathing, coughing exercises and use an incentive spirometer to help protect your respiratory system.
- Your dressing and incision will be checked regularly. If you have sutures or staples, they are usually removed at your first follow-up visit with your surgeon.
- You may have a small tube that is connected to a wound drain or collection container. It will draw out excess blood and fluid from the area around your incision. This small tube will be removed the day after surgery.
- You will have an intravenous (IV) line that will be removed before you leave the hospital (discharge). It is important to drink 6 to 8 glasses of liquid each day.
- Your inactivity and pain medicine combined can cause constipation. To help prevent this:
 - Drink plenty of liquids.
 - Eat foods with plenty of fiber including whole-grain bread, bran cereals, fresh fruit and vegetables.
 - Increase your activity as you are able.

Talk to a member of your health care team about a bowel program if you are uncomfortable and the actions above are not working. You may receive a stool softener medicine to help prevent constipation.

Ask a member of your health care team if you have questions about these care activities.

How to Use an Incentive Spirometer



An incentive spirometer is a hand-held breathing exercise device to help you breathe deeply.

Incentive spirometer

After surgery, it may be difficult to breathe as you normally do. You may notice your breathing changes to small, shallow breaths. This can cause fluid and mucus to build up in your lungs, increasing your risk for respiratory system complications.

An incentive spirometer is a hand-held breathing exercise device to help you breathe deeply. Taking deep breaths allows air to inflate your lungs, opening your airways to prevent fluid and mucus buildup.

Using an incentive spirometer may speed your recovery and lower your risk of lung problems such as pneumonia.

How to use the incentive spirometer

1. Sit upright in a chair with your feet flat on the floor. (If you are not able to sit up in a chair, sit as upright as possible.)
2. Place the spirometer on your bedside table or hold it in an upright position.
3. Place the mouthpiece in your mouth. Seal your lips tightly around the mouthpiece.
4. Inhale as slowly and deeply as possible through the mouthpiece. Your health care provider will work with you to set a breathing goal, which will be marked with small arrows on the incentive spirometer. As you inhale, the small square should stay between the arrows.
5. Hold your breath for 3 to 5 seconds. Then exhale slowly through pursed lips. (Pursed lips are in the shape of blowing out a candle.)
6. Repeat 10 times, resting between each time.
7. It is important to cough to clear any secretions. Coughing (clearing your airway) will make breathing easier. It will also strengthen your muscles after each use.

How often you need to use the incentive spirometer

- **At the hospital:** You will need to use the incentive spirometer 10 times every hour you are awake after surgery.
- **At home:** You will need to use the incentive spirometer 10 times every 2 hours for your first 7 days at home.

Tips to Prevent Falls While You Are in the Hospital

Remember: Certain medicines, general weakness, and new surroundings during your hospital stay can increase your risk of falling.

Tips to prevent falls

1. For your safety, a member of the nursing staff will stay within arm's reach with you in the bathroom and when you are walking.
2. Wear nonslip footwear (red slippers) when you are up.
3. Other things that may be used to keep you safe in the hospital include a bed alarm, chair pad alarm, floor mat or observation camera.
4. Use the call light when you need help.
5. Ask the nursing staff for help to and from the bathroom. This is very important if you are unsteady. The call light in the bathroom may be located on the wall.
6. If you take medicines that cause you to go to the bathroom often, ask for help when you need to get up. Consider using a commode or urinal.
7. Some medicines may cause you to feel dizzy or sleepy. Take your time getting out of the bed or chair. Sit at the edge of the bed for a few seconds before you get up.
8. Wear your eyeglasses, hearing aid(s) or both when you are awake.
9. Walkers and canes can provide support. Other items do not. Do not lean on the bedside table, furniture, IV pole or other items to steady yourself.
10. Ask a member of your health care team to place the call light, phone and personal items within your reach before he or she leaves the room.
11. Tell a member of the nursing staff if you have any concerns about your safety.

Tip

See chapter 6 for more information about special equipment you may need after your surgery.



Chapter 4: Care After Surgery

After your surgery, there are things you need to know for your safety, recovery and comfort. You will receive instructions on your nutrition, medicines, exercise program, activity level, discharge equipment, follow-up appointment, and signs and symptoms to watch for.

Within this chapter is what to expect during your recovery, a list of commonly asked questions, a list of questions to ask at your follow-up appointment, and information about pain relief, pain medicines, anti-inflammatory medicines, constipation and nutrition.

Ask your health care team if you have any questions. They want your recovery to be as smooth as possible.

What to Expect During Your Recovery

Important

Swelling after surgery is common. Reducing the amount of swelling may also reduce the amount of pain you have.

Important

Based on your needs after surgery, your surgeon may recommend a follow-up appointment with your primary care provider 5 days after you leave the hospital.

Before you leave the hospital

- Talk with your surgeon about any precautions you may have after surgery.
- Make sure you have a follow-up appointment scheduled with your surgeon 10 to 14 days after your surgery.

Important: It can take a while to heal after surgery. Recovery is different for each person.

Day you leave the hospital to 3 weeks after surgery

- Your surgeon and physical therapist will talk with you about your home exercise program. Follow any instructions he or she gives you. This will have a big impact on your recovery.
- Swelling after surgery is common. You may experience the most swelling 7 to 10 days after surgery.
 - Raise (elevate) your leg above the level of your heart by placing a pillow under your calf or ankle, not your knee.
 - Apply a cold pack for 15 to 20 minutes, several times throughout the day to help reduce swelling.
 - Call your surgeon right away if you have an increase in calf pain.
- You will likely have a decrease in energy after surgery. Make sure to balance your activity with rest and continue with your home exercise program.

- You will have some pain, discomfort and stiffness after surgery. It is important to create a pain plan to follow at home. Follow your surgeon's instructions for pain medicine.
- You may not feel like eating for the first few weeks after surgery. However, good nutrition is essential for your recovery. Try to resume eating healthful meals and snacks as soon as you are able. Make sure to drink six to eight 8-ounce glasses of liquids each day and include protein (meat, poultry, fish, beans, nuts and seeds) in your meals and snacks to help your body heal.
- You may have constipation. This can be caused by taking pain medicine. Talk with your surgeon about ways to manage constipation.
- You may feel some numbness in the skin around your incision. This should get better over time.
- Timing of when to take medicines is important.
 - Do not wait for pain to get worse before taking medicine. Tablets or pills may take up to 30 minutes to begin working.
 - If you know your pain may get worse with activity, take your pain medicine before the activity.
- You may also try non-medicine ways to relieve pain such as:
 - relaxing
 - listening to music
 - changing positions
 - elevate and ice
 - walking
 - distractions (reading, watching TV, talking on the phone or with visitors)
 - aromatherapy.

Three to 6 weeks after surgery

- Continue with your home exercise program. This will have a big impact on your recovery.
- You may continue to have pain, discomfort, stiffness and swelling. This is common and should get better over time. Continue treating with elevation, ice and other non-medicine ways to treat pain. (Most people are off pain medicine unless they were already taking pain medicine before surgery.)
If you feel new pain or your pain gets worse, call your surgeon right away.

Important

Opioid pain medicine should only be used as directed to help relieve pain. Do not take your pain medicine to help you sleep better. Please call your surgeon if you have problems sleeping.

- It is common to have trouble sleeping. It may be helpful to:
 - avoid sleeping or napping too much during the day
 - create a routine of going to bed and waking up at the same time each day
 - changing positions in bed
 - avoid drinking too many liquids right before going to bed
 - avoid stress before bed.

Call your surgeon if you continue to have problems sleeping.
- You may start walking without an assistive walking device when your surgeon says it is OK.
- You may be able to do most activities around the house if your surgeon says it is OK.
- You may be able to drive if:
 - you are not taking pain medicine
 - your surgeon says it is OK.
- You may resume sexual activity when you are ready.
 - A firm mattress is recommended.
 - Be the passive partner for the first 6 weeks after surgery.
 - Follow your hip precautions if you have them.
 - Visit recoversex.com for more information about resuming sexual activity.
- You may be able to return to work 4 to 6 weeks after surgery, depending on your type of work. You may want to consider going back to work gradually and starting with half days. Remember to take rest breaks and find time to elevate and ice your leg to prevent swelling.
- Your surgeon may want you to schedule an appointment 6 weeks after surgery to have your incision checked and talk about physical activity.

Ten to 12 weeks after surgery

- You should be able to resume most of your regular activities if your surgeon says it is OK. Some activities such as jogging, jumping and aerobics put a lot of strain or pressure on your new joint and should be avoided. Check with your surgeon before starting any new activities.

Three to 6 months after surgery

- Ask your surgeon when it is OK to resume having routine dental appointments or any dental work done.
- Your surgeon may want you to schedule an appointment 6 months after surgery to talk about your recovery and do an X-ray if needed.

Six months to 1 year after surgery

- Most of your pain should be gone 1 year after surgery. However, you may still have some swelling in your lower leg and foot, and discomfort going up and down stairs or sitting in one position for too long. It is important to be physically active and maintain a healthy weight for the best recovery.
- You may resume playing low-intensity activities. Talk with your surgeon about which activities are right for you.

Commonly Asked Questions

Emergency Symptoms

Call 911 or have someone take you to the nearest hospital Emergency Department if you have any of the following:

- chest pain
- trouble breathing or painful breathing
- shortness of breath.

Important

Please call your surgeon if you fall — even if you do not think you hurt yourself.

When should you call your surgeon?

Call your **surgeon** if you have:

- a temperature of 101.6 F or higher
- problems or signs of infection at your incision site such as:
 - increased pain
 - increased swelling
 - increased redness
 - odor
 - warmth
 - green or yellow discharge
- any change in your ability to move such as new weakness, or not being able to move your arm or leg
- signs and symptoms of a blood clot including pain, swelling, tenderness, warmth or redness in the back of one or both lower legs (calves)
- any change in sensation such as new numbness or tingling
- any unusual bruising or bleeding
- severe pain not relieved by medicine, rest or ice
- any problems, questions or concerns related to your surgery.

When should you call your primary care provider?

Call your **primary care provider** if you have:

- feelings of being dizzy, lightheaded or confused
- an upset stomach (nausea) and throwing up (vomiting) that will not stop
- any bowel problems such as constipation or bloody stools
- any problems urinating such as burning, urgency or frequency
- any other problems, questions or concerns.

What are signs and symptoms of an infection?

Signs and symptoms may include:

- increased redness, swelling or warmth at the incision site
- change in color, amount, odor of drainage
- increased pain in the knee
- temperature higher than 101.6 F.

Call your surgeon's office if you have any of the above signs or symptoms.

What are signs and symptoms of a blood clot?

Signs and symptoms may include:

- swelling in one or both legs
- pain or tenderness in one or both legs
- warmth of the skin in the affected leg
- redness or discolored skin in the affected leg
- leg fatigue.

Call your health care provider if you have any of the above signs or symptoms.

What are signs and symptoms of a pulmonary embolism?

Signs and symptoms may include:

- shortness of breath
- sharp chest pain that may get worse with deep breathing or coughing
- confusion
- sweating
- signs of shock.

Call 911 right away if you have any of the above signs or symptoms.

How do you take care of your incision and change the dressing?

- You should look at the area around your incision every day and keep it clean while it heals.
- Do not put any lotions, creams, salves, powders or ointment on your incision site.
- Follow your discharge instructions given to you by your surgeon. Ask him or her if you have questions.

How soon can you take a bath or shower?

- You may go home with a waterproof dressing covering your incision. You can shower with this dressing on if the edges are not peeling back.
- If you do not have a waterproof dressing and you still have sutures, staples or stitches, you can cover your incision with plastic to keep it dry while taking a shower.
- Ask your surgeon when your incision can get wet.
- You can take a shower as soon as you feel confident to do so.
- Using a tub or shower chair in the bathtub or shower may offer you extra support and comfort until you are able to become more able to move around (mobile).
- Do not take a tub bath until your surgeon says it is OK. (This also includes swimming in pools or lakes and using hot tubs.)

How do you manage constipation after surgery?

Constipation is common after surgery. It can be caused by pain medicines, iron supplements, decreased daily activity and changes in eating habits. See pages 74 to 75 for more information about constipation.

When can you return to your normal diet?

As soon as you are able, eat well-balanced meals and snacks to help you recover more quickly and to help you feel your best. What you eat after your surgery affects your well-being. You need to eat healthful foods and drink a lot of liquids. See pages 76 to 78 for more information about nutrition.

Will you set off metal detectors in airports?

If your joint replacement has metal, it may set off the metal detectors in airports. It is recommended to tell the security officer that you have a metal implant and where it is located before you go through security screening. The security officer may offer you a private security screening

Important

Ask your surgeon when it is OK to resume having routine dental appointments or any dental work done.

Did You Know?

Germs (bacteria) that can cause infections in your teeth or gums can be released into your bloodstream during some dental procedures.

More Information

Visit recoversex.com for more information about resuming sexual activity after surgery.

Do you need to take preventive antibiotics before surgery, procedures or dental work?

Tell health care providers and dentists of your hip replacement **before** having any surgery, podiatry procedures, dental work, X-rays, or other tests or procedures. You may need to take antibiotics.

Dental work

To help prevent an infection, you may need to take antibiotics before dental work. Talk with your dentist and surgeon so they can work together to decide which type of treatment is right for you.

When can you drive a car?

- Talk with your surgeon about when you can resume driving.
- You should wait to drive a car until after your first follow-up appointment with your surgeon.
- Do not drive while taking pain medicine because it can impair your judgment and ability to operate the car safely.
- Do not use your surgical leg to operate machinery until 6 weeks after surgery.

When can you return to work or your hobbies?

Discuss returning to work or hobbies with your surgeon.

When can you resume sexual activity?

- You can resume sexual activity when you are ready.
- A firm mattress is recommended.
- Be the passive partner for the first 6 weeks after surgery.
- Use the missionary position or less dominant position.

When do you need to have your first follow-up appointment with your surgeon?

Call your surgeon's office for a surgery follow-up appointment if you do not already have one or if you have any questions or concerns. See the worksheet on the next page about questions to ask your surgeon at this appointment.

Questions to Ask at My Follow-up Appointment

How much longer should I:

take my pain medicine: _____

Should I make any changes to the amount of pain medicine I am taking?

take my blood thinner medicine: _____

Can I do the following:

take a tub bath

begin walking with crutches or a cane (assistive walking device)

How long can I expect to walk with one? _____

drive a car

If no, when can I expect to drive a car? _____

travel on an airplane

If no, when can I expect to travel on an airplane? _____

increase my leisure activities such as traveling, golfing or dancing?

If no, when can I expect to increase my activities? _____

Do I need to take antibiotics for any dental care or medical procedures?

If I was given activity precautions, how long do I need to follow them? _____

When can I return to work? _____

Other questions:

Pain Relief

For More Information

Keeping your pain managed continues when you leave the hospital.

For more information on keeping your pain managed, visit allinahealth.org/painvideos to watch a series of four short videos on pain.

The topics are:

- pain expectations
- how to use the pain scale
- how to treat pain in the hospital
- how to keep your pain managed at home.

You can watch the videos as often as you would like.

Your pain should lessen every week. There are many ways you can ease your pain:

- Go for a walk a few times each day.
- After activity (exercises or walking) lie down and apply a cold pack to your incision. This can help reduce swelling and pain.
 - Use a clean, dry towel on your skin before you place the cold pack. Leave the cold pack on for 15 to 20 minutes at a time.
 - Use cold packs several times throughout the day.
- You may feel some discomfort in your leg. Raise (elevate) your leg above the level of your heart by placing a pillow under your calf or ankle, not your knee. You can also try massage, aromatherapy, music therapy or other non-medicine ways to relieve pain.
- Take your prescription pain medicine as directed.

Pain Medicine: What You Need to Know

Important

Opioid pain medicine should only be used as directed to help relieve pain. Do not take your pain medicine to help you sleep better. Please call your surgeon if you have problems sleeping.

How to take opioid medicine

- Take the medicine as directed by your health care provider.
- Eat before you take the medicine.
- Drink plenty of water with the medicine.
- Write down when you take the medicine and how many pills you take.
- **Do not drive when you are taking the medicine.** The medicine will affect your ability to make decisions or react quickly.
- **Do not drink alcohol when you are taking the medicine.**
- Use it only for the first few days or weeks when the pain is most intense. Talk with your health care provider for a taper plan.
- Put your opioid medicine in a secure place to prevent others from using it.

Important

The longer you take opioid pain medicines the more risk there is of becoming dependent (addicted). While opioid pain medicines can help you feel less pain after surgery, injury or illness, you need to partner with your health care provider and transition to other ways to relieve pain.

When taking opioid pain medicine, find a balance between the amount of pills you take and the pain level with which you are able to cope. It is better for you to be active and tolerate mild pain than it is to take so much pain medicine that you sleep too much or that you are stuck in bed or a chair.

Important

It is important that you call your pharmacy **several days before** you run out of your pain medicine. Your health care provider will need to sign for (authorize) your refill request before it is filled.

Opioid benefits and risks

Potential benefits are:

- The medicine works quickly.
- You will feel less pain.
- You will be able to be active to speed your recovery. For every day you stay in bed, you need 3 days to regain your strength.
- You will be able to rest or sleep better.

Potential risks are:

- Taking an opioid can lead to addiction.
 - On average, more than 130 people die each day in the U.S. from an overdose of opioids, according to the Centers for Disease Control and Prevention.
- The longer you take opioids, the more your body gets used to it (known as tolerance), and two things happen:
 - They may not work as well.
 - You may have more side effects when you stop them.

These are not problems in the first 3 days of use.

- Taking too many opioids can cause side effects, such as:
 - feeling dizzy, itchy or both
 - making you feel groggy or sleepy
 - feeling sick to your stomach
 - throwing up
 - being unable to have a regular bowel movement (constipation)
 - having breathing problems.
- Some opioids contain acetaminophen (Tylenol[®]), such as Norco[®] or Percocet[®]. Acetaminophen is an over-the-counter medicine. Do not take more than 4,000 mg of acetaminophen in 24 hours.
 - Allergic reactions to opioids or acetaminophen include:
 - hives, itching or a flushing feeling
 - swollen lips, tongue or both
 - nasal congestion, feeling like your throat is closing or choking
 - shortness of breath, wheeze or cough
 - feeling faint, lightheaded, dizzy or having a racing heart
 - upset stomach, throwing up, diarrhea (loose stools) and belly pain.

- You may be at a higher risk for side effects (including accidental death) if you have sleep apnea, drink alcohol, or if you take a benzodiazepine (sedative) medicine while taking an opioid.

How to cut back (taper) an opioid

Take your recommended doses when your pain is at its worst. Slowly cut back (taper) on the opioid pain medicine once you can cope with the pain by using other ways to manage your pain. Ask your health care provider for directions on how to taper. Be sure you know how long you should take the medicine.

How to get rid of unused opioids

Do not keep unused medicine “in case” you think you may need it. Having it in the house where other adults, children or pets could reach it is unsafe.

- To get rid of unused opioids, bring them to a drop-off location or to an Allina Health Pharmacy. To find a location near you:
 - **Minnesota:** Go to pca.state.mn.us and type “household hazardous waste” in the search box.
 - **Wisconsin:** Go to dnr.wi.gov and type “health care waste” in the search box.
- If you can’t get to a disposal site:
 - Scratch off your name, your provider’s name and the prescription number on the medicine label. Or, scribble the information out with a black marker.
 - Add a small amount of vinegar to dissolve most of the pills. (Do not flush the pills.)
 - Tape the cap of your medicine container shut with a strong tape.
 - Put the taped medicine container in a paper bag or other container that you cannot see through (such as an empty yogurt, sour cream or coffee container).
 - Throw the container in the garbage, not in the recycling bin.

When to call your health care provider’s office

Call your health care provider if you have:

- side effects or problems
- new pain
- questions or concerns.

Anti-inflammatory Medicines

Important

Talk with your surgeon before starting an anti-inflammatory medicine.

You may have been started on anti-inflammatory medicines such as ibuprofen (Advil[®], Motrin[®]) or celecoxib (Celebrex[®]) during your recovery in the hospital. Anti-inflammatory medicines help with healing by reducing swelling and pain.

If you will be continuing an anti-inflammatory medicine after leaving the hospital, be aware that these medicines may cause stomach upset for some people. Take the medicine as directed on your prescription. **Take medicine with food or milk to prevent stomach upset or other problems (complications).** Call your health care provider if you have any questions or concerns.

Constipation

Constipation is common after surgery, especially while you are taking pain medicine and your daily activity level is decreased.

Signs of constipation include:

- fewer number of bowel movements
- small, hard stools you have trouble passing
- feeling bloated and uncomfortable
- gas
- abdominal cramping

How to prevent constipation

- Drink six to eight 8-ounce glasses of liquids each day. Liquids add moisture to stool, making them easier to pass. Water is your best choice. Caffeine or alcohol can make constipation worse.
- Eat more high-fiber foods such as whole-grain bread, bran cereals, fresh fruit and vegetables.
- Be as active as you can each day. Walking around your house or apartment will help. Follow your health care provider's instructions for exercise.
- Try to have a bowel movement when you feel the urge. Do not ignore the urge. Try to set aside some time after breakfast or dinner to sit on the toilet.
- Take less pain medicine if possible. Follow your surgeon's instructions for taking pain medicine.

Tip

- You can buy laxatives and stool softeners at most local grocery stores, drugstores and large retailers.
- Read the label carefully and follow package directions. Talk with your pharmacist if you have any questions.
- Stop taking a laxative or stool softener when your bowel movements are back to normal.

Use of constipation medicines

You may need to take a laxative to prevent constipation as long as you are taking prescription pain medicine. Common products include:

- **stimulant laxatives.** These cause the colon to have a bowel movement. This is the best choice when your constipation is caused by a prescription pain medicine. An example is bisacodyl (Dulcolax[®], Correctol[®]).
- **stool softeners.** These add moisture to the stools to make the stool softer and easier to pass. These may not be enough to prevent constipation while you are taking a prescription pain medicine. An example is senna (Senokot[®]).

When to call your primary care provider

Call your primary care provider if:

- your constipation does not improve after you have:
 - made changes to what you are eating
 - made exercise changes
 - tried laxatives or stool softeners
- you have not had a bowel movement in 3 days
- you have a severe, sudden onset of abdominal pain
- you have blood in your stool.

Nutrition: What You Need to Know

Tip

According to the United States Department of Agriculture, you should:

- eat smaller portion sizes
- make half of your grains whole
- make half of your plate vegetables and fruits
- drink fat-free or low-fat milk
- eat lean proteins.

Visit choosemyplate.gov for more information about nutrition.

Important

Ask your health care provider if you have questions about your nutrition and recovery.

Tip

Be sure to drink six to eight 8-ounce glasses of liquids (especially water) each day.

Good nutrition is essential for your recovery. Eating well-balanced meals and snacks will help you recover quickly and help you feel your best. What you eat after surgery affects your well-being.

If you do not eat enough of the right foods, you will become tired and less able to take care of yourself. Be sure you make time to eat — even if you do not feel hungry.

Try to think about what your plate should look like when you are planning your meals and snacks.

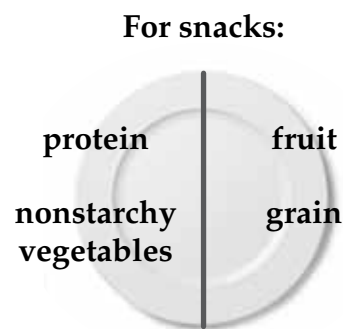
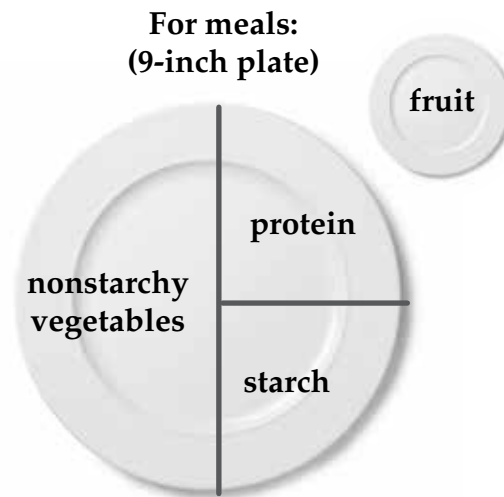

Here are some examples of well-balanced meals and a snack.

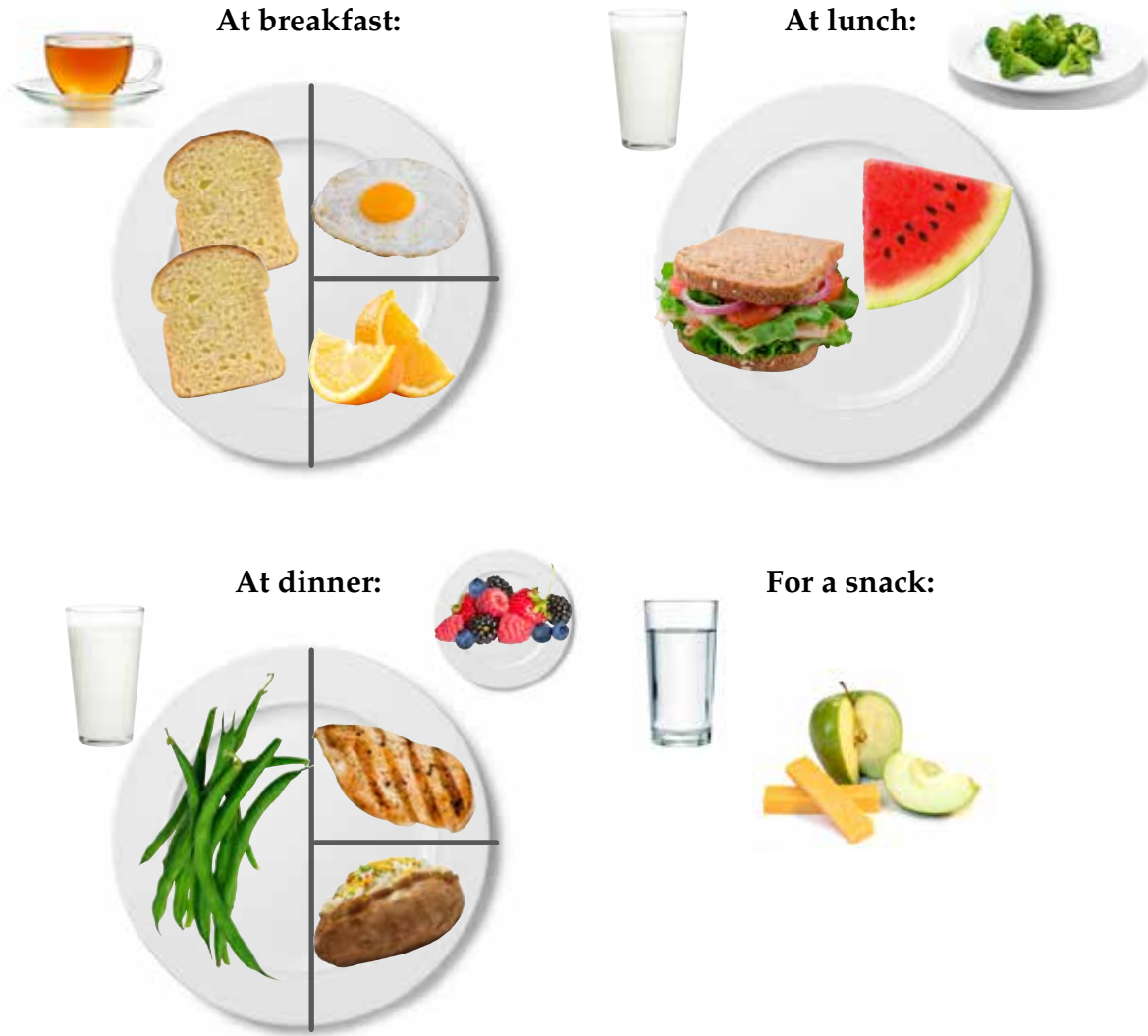

Tip

Eat foods high in vitamin C to help absorb the iron that comes from plants such as spinach.

For instance, drink a glass of orange juice with an iron-fortified cereal.

Good sources of vitamin C are oranges, broccoli, tomatoes, kiwi, strawberries, peppers, potatoes and cabbage.

























Nutrients important for your recovery

Eating foods rich in the following nutrients are important for your recovery.

- **Protein:**
Protein helps repair and build healthy tissue.
- **Iron:**
Iron works in each of your body's cells to help make energy.
- **Vitamin C:**
Vitamin C helps your body repair damaged tissues, keeps your bones and teeth strong, and helps your body absorb iron.
- **Calcium:**
Calcium helps build and maintain your bones, your muscles move, your blood clot and your nerves send messages.
- **Fiber:**
Fiber helps your body produce regular bowel movements.

Use the chart on the next page to help you choose foods for building well-balanced meals and snacks.

The following chart shows examples of foods to put on your plate.

Protein	Iron	Vitamin C	Calcium*	Fiber**
 Chicken	 Peas	 Tomatoes	 Milk	 Brown rice
 Tofu	 Raisins	 Oranges	 Yogurt	 Sweet potato
 Eggs	 Steak	 Berries	 Almonds	 Whole-grain pasta
 Peanut butter	 Bran flakes	 Bell peppers	 Sardines	 Whole-grain bread
 Salmon	 Beans and legumes	 Cantaloupe	 Broccoli	 Whole-grain wrap

*If you cannot tolerate milk products, you can also drink calcium-fortified juices such as orange juice. Choose low-fat or fat-free milk products.
**Choose whole-grain varieties.

Chapter 5: Home Exercise Program

Tip

See chapter 2 for more specific information about mobility techniques.

Your leg muscles may feel weak after surgery because you did not use them much with your hip problems. Surgery corrected the hip problem. Your home exercise program will include activities to help reduce swelling and increase your hip strength. This will help you move easier and get back to doing the activities you enjoy.

Your success with rehabilitation largely depends on your commitment to follow the home exercise program (on the following pages) developed by your therapists.

Swelling

It is important to try to keep your swelling down after surgery. You will be able to do this by:

- lying flat with your leg at the level of your heart
- putting a cold pack on your hip
- actively pumping your muscles through ankle pumps
- balancing activity with rest.

Page 82 has instructions on how to do these activities.

Tip

Do your exercises lying down for the most comfort. Your bed is an excellent place to do your exercises.

Strengthening activities

It is important to work on regaining strength after hip surgery. This will help you get back to doing the things you enjoy. You will be able to do this by doing leg strengthening exercises as instructed by your physical therapist.

See pages 83 to 84 for instructions on how to do these activities.

Walking

It is important to walk often throughout the day. This will help you get back to walking outside and in the community. You will be able to do this by:

- walking around your home using a front-wheel walker, crutches or a cane (assistive walking device) your therapist instructed you to use
- walking with the “heel-toe” pattern that your therapist taught you (to help keep you from walking with a limp)
- gradually increasing the distance you walk.

See page 85 for instructions on how often to walk.

Follow any additional instructions given to you by your health care provider or therapist.

Swelling

Do these activities to help reduce the amount of swelling and improve circulation after surgery.

How often: At least 3 times a day

You will have swelling in your leg and foot after surgery. Your swelling may increase after you leave the hospital. This is common and should gradually go away. It is important to try to keep your swelling down. The activities below will help you with managing swelling and pain.

Rest and elevate

- Lie down with your surgical leg at or above the level of your heart for at least 20 minutes.
- You may place two to three pillows lengthwise beneath your surgical leg if you have an increase in swelling. Call your surgeon if you are concerned about the amount of swelling you have or if your swelling does not improve.

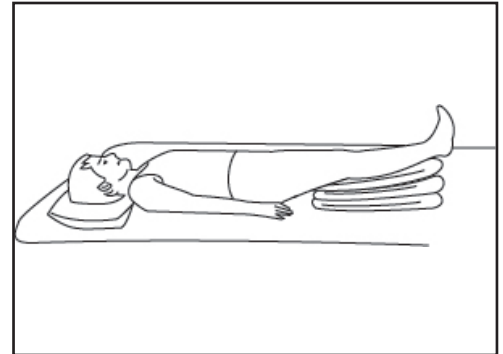

Lie on your back and elevate your leg using pillows when icing and doing ankle pumps.

Ice

- While you are resting and elevating, place cold packs around your hip for 15 to 20 minutes at a time.
- Place a clean, dry towel or pillowcase between your skin and the cold pack.

Ankle pumping for circulation

Do the following exercises 10 times each while you are lying down resting.

- **Ankle pumps and circles**
Pump your feet up and down by pulling your feet up toward you, then pushing your feet down away from you. In addition, rotate your feet clockwise and counterclockwise. **Ankle pumps should also be done 10 times every hour while you are awake.**

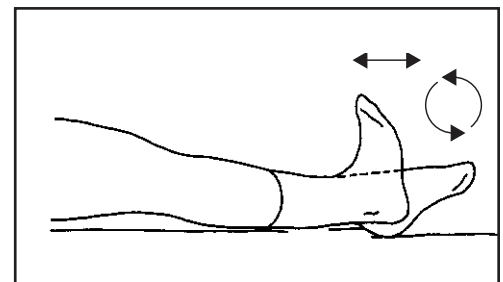

Drawings © Allina Health System

Activity

- It is important to gradually increase your out-of-home activity during the first few weeks after surgery. If you do too much activity, your hip may become more swollen and painful.

Strengthening

Do these exercises to strengthen your muscles.

How often: 2 to 3 times a day

Do 10 repetitions of each exercise. If you are comfortable with the exercises, gradually increase the number of repetitions until you reach 20 repetitions.

Do your exercises lying down for the most comfort. Your bed is an excellent place to do your exercises.

Ankle pumps

Pump your feet up and down by pulling your feet up toward you, then pushing your feet down away from you.

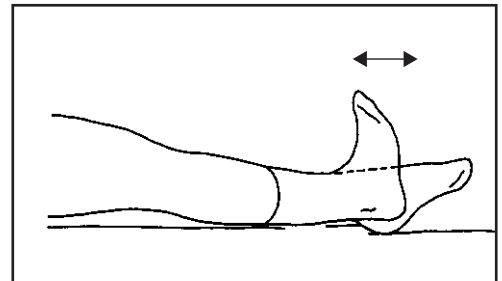

Thigh squeezes (quadriceps sets)

Tighten the muscles on the top of your thigh by pushing the back of your knee down into the bed. **Hold for 5 seconds and relax.**

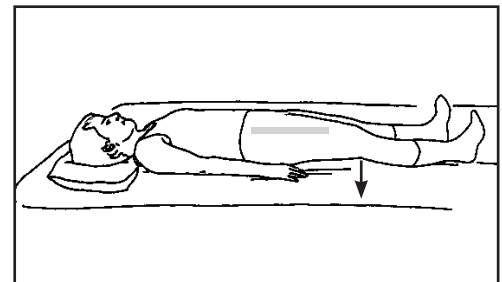

Buttocks squeezes (gluteal sets)

Tighten your buttocks muscles by squeezing the muscles together. **Hold for 5 seconds and relax.**

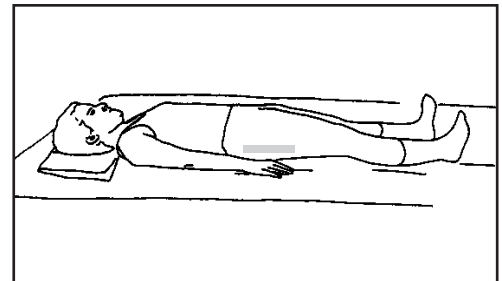

Heel slides (hip and knee flexion)

Bend your surgical hip and knee by sliding your heel up toward your buttocks while keeping your heel on the bed. Slide your heel back down to the starting position and relax. Keep your kneecap pointed up toward the ceiling during the exercise. You may want to use a plastic bag under your heel to help it slide easier.

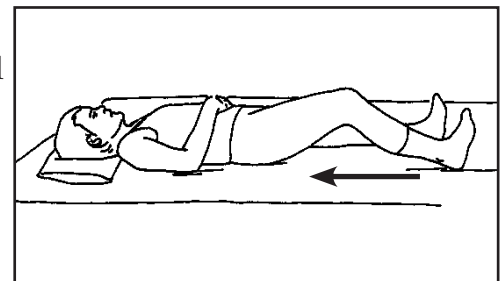

Drawings © Allina Health System

❑ Leg slides (abduction/adduction)

Slide your surgical leg out to the side, keeping your kneecap pointed up toward the ceiling. Slide your leg back to the starting position. You may want to use a plastic bag under your heel to help it slide easier.

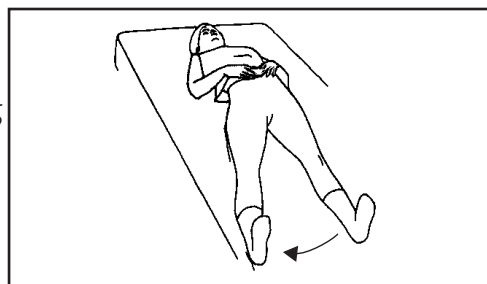

❑ Lying kicks (short arc quadriceps)

Lie on your back with a rolled-up blanket or towel (at least 6 inches in diameter) under the knee of your surgical leg. Straighten your surgical leg. **Hold for 5 seconds.** Slowly lower your leg down and relax. The back of your knee should stay in contact with the blanket or towel during the exercise.

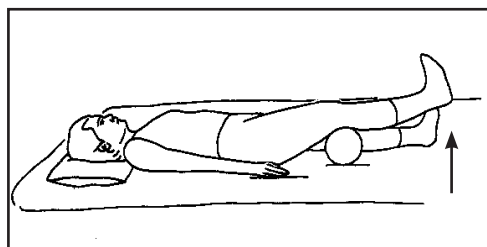

❑ Straight leg raises

Bend your non-surgical leg with your foot flat on the bed. Tighten the muscles on the top of your thigh, stiffening your knee. Raise your surgical leg up (about 12 inches), keeping your knee straight. **Work up to holding for 5 seconds.** Slowly lower your leg down and relax.

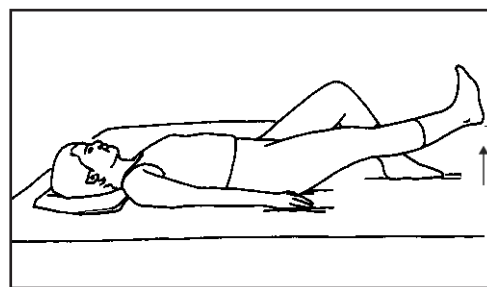

❑ Sitting kicks (long arc quadriceps)

Sit on a sturdy chair or on the side of your bed. Straighten your knee. **Hold for 5 seconds.** Slowly lower your leg down and relax.

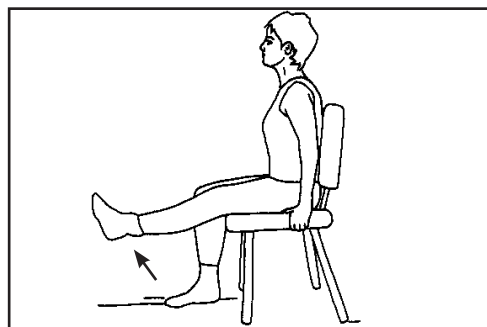

Drawings © Allina Health System

Walking

How often: 5 times a day

Besides your exercise program, you must leave time for walking. It helps build your strength and endurance.

- **Walk around your home 5 times a day.** Trips to the bathroom or kitchen are not enough.
- Gradually increase the distance you walk. Work up to walking outside and in the community.

Keep in mind that each person is different and has different pre-surgery levels of fitness. Talk with your physical therapist about walking if you have additional medical conditions.

Standing Exercises

Do these exercises only if instructed by a therapist or your surgeon.

Stand next to a kitchen counter or table, and hold on securely. Stand up straight during these exercises and do them in a slow and controlled movement.

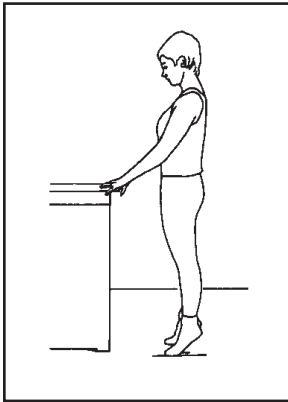

- ❑ Raise up onto the balls of your feet.

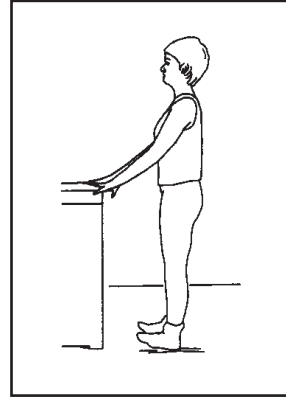

- ❑ Raise your forefeet off the floor.

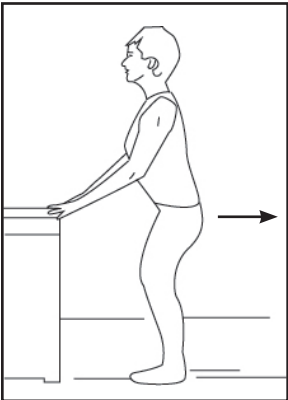

- ❑ Bend your knees slightly, by sitting back with your hips.

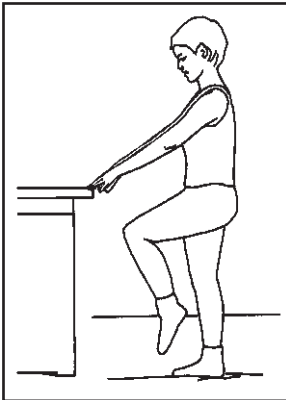

- ❑ Bend your knee as you bring it up toward the ceiling.

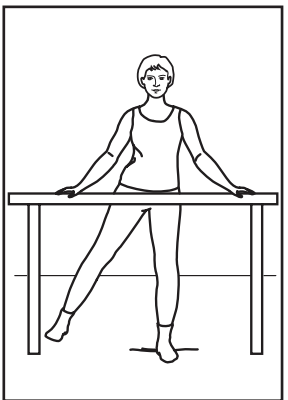

- ❑ Lift your leg out to the side.

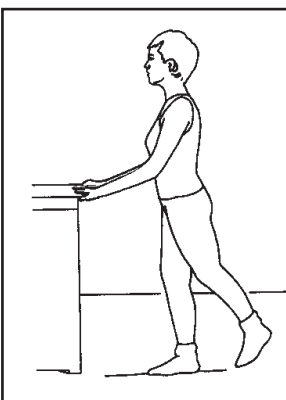

- ❑ Lift your leg slightly backward, while squeezing your buttocks. Keep your knee straight.

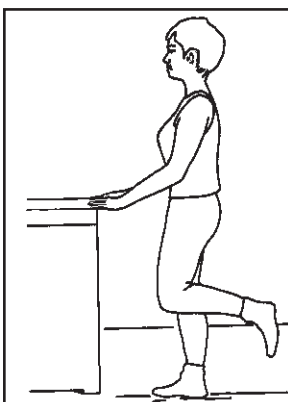

- ❑ Bend your knee, as you bring your heel up toward your buttocks.

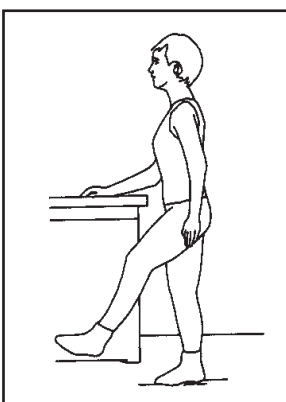

- ❑ Lift your leg forward off the ground. Keep your knee straight.

Additional Exercises

Do these exercises only if instructed by a therapist or your surgeon.

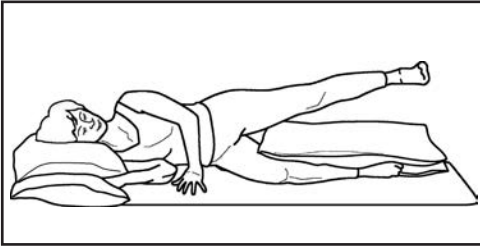

Side leg lifts (abduction/adduction)

Lie on your non-surgical side with a pillow between your legs. Lift your surgical leg straight up to the side. **Hold for _____ seconds.** Slowly lower your leg down and relax. Repeat _____ times.

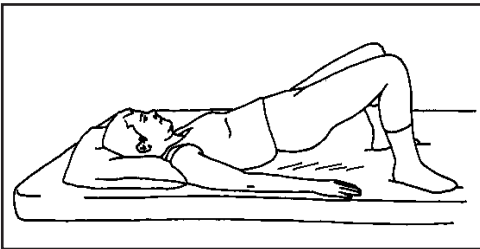

Bridging

Slowly raise your buttocks from the bed, keeping your stomach muscles tight. **Hold for _____ seconds.** Slowly lower your buttocks down and relax.

Drawings © Allina Health System

Home exercise program — hip replacement

Check the box under the appropriate day and week after you perform the exercises selected for you.

Exercise	Week 1							Week 2							Week 3							Week 4						
	M	T	W	Th	F	S	S	M	T	W	Th	F	S	S	M	T	W	Th	F	S	S	M	T	W	Th	F	S	S
Ankle pumps																												
Thigh squeezes																												
Buttocks squeezes																												
Heel slides																												
Leg slides																												
Lying kicks																												
Straight leg raises																												
Sitting kicks																												
Standing exercises																												
Additional Exercises																												
Side leg lifts																												
Bridging																												

Chapter 6: Resources

Medical Equipment

Important

Your surgeon may have activity precautions for you to follow after surgery. The following equipment will help you follow these precautions while doing self-care activities. Your physical therapist will help you understand your precautions.

You may need to use some special equipment to ensure a safe recovery after your surgery. This page and the following page show and describe the equipment.

You must use a front-wheel walker or crutches (assistive walking device) after your surgery. Any other items are optional based on your needs. Insurance may cover a walker or pair of crutches.

See the “Community Resources Directory” in this chapter for information about places that loan or sell equipment.

Front-wheel walker or crutches



A front-wheel walker or crutches will help you feel more stable as you walk.

Raised toilet seat or commode



A raised toilet seat will make it easier for you to get on and off the toilet.

Shower chair

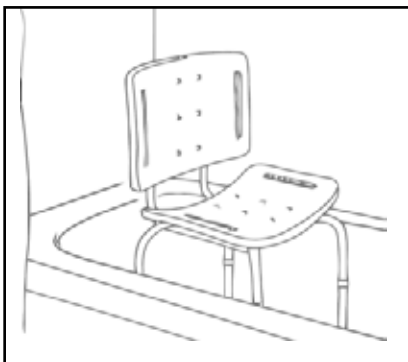

A shower chair lets you sit while taking a shower.

Toilet safety frame

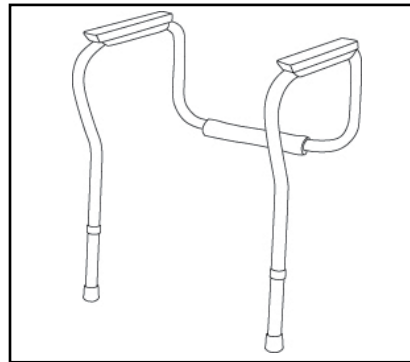

A toilet safety frame will make it easier for you to get on and off the toilet.

Tub transfer bench



A tub transfer bench can help you get in or out of the shower or tub. You can also sit on it while taking a shower.

Sock aid

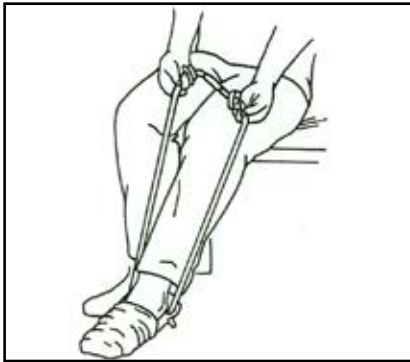

A sock aid helps you put on socks without bending.

Tongs

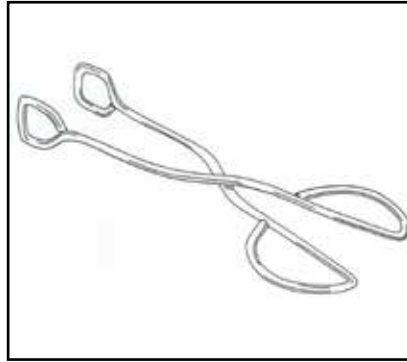

Tongs can be used in place of a reacher. Or they can help you with your hygiene care after you use the toilet.

Elastic laces or long-handled shoe horn

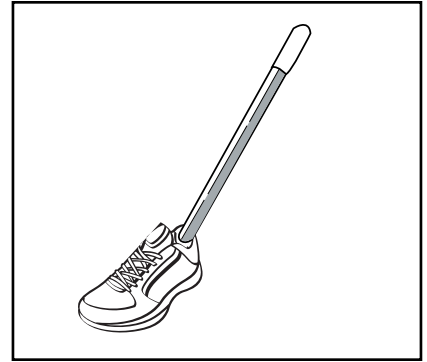

Elastic laces let you slip in and out of your shoes easily while keeping them tied. The long-handled shoe horn helps you guide your foot into an already-tied or slip-on shoe.

Hand-held shower head

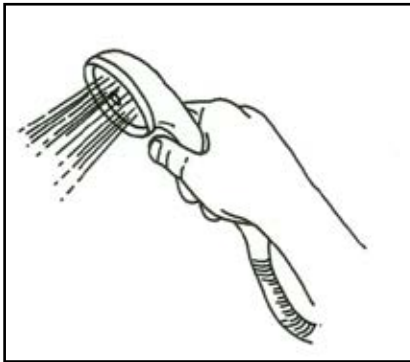

A hand-held shower head allows you to control the spray of water while sitting.

Long-handled sponge

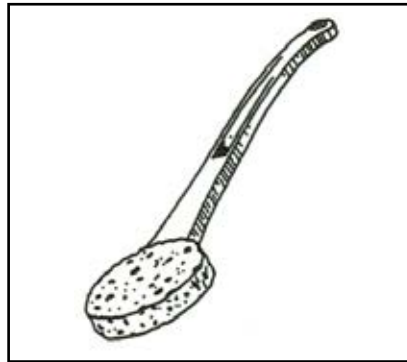

A long-handled sponge can be used to wash your feet when you cannot bend and to wash your back so you keep from twisting.

Reacher

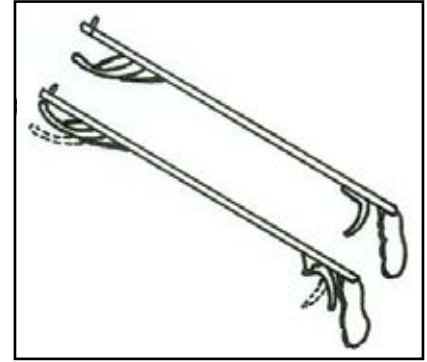

A reacher helps you get things from higher and lower levels. It can also help you put clothes on the lower part of your body.

Grab bars

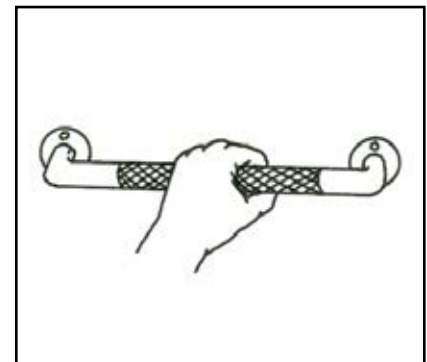

Installing grab bars around your toilet, bathtub or shower will increase your safety during transfers.

Important

Do not use grab bars with suction cups. The suction cups can slip off and cause a fall. Instead, have them installed securely into the wall.

Community Resource Directory

Allina Care Navigation Help Desk

Call 612-262-2200 or 1-855-227-5111 if you have questions about community resources, medical equipment or home care.

Medical equipment

Certain equipment can make your recovery go easier and increase your independence after your surgery. Try to get your equipment before you have surgery. You may want to borrow the items from family or friends if possible.

The following is a list of resources to help you find the equipment you need.

- AdaptHealth Minnesota offers items to buy. Call 651-628-4800 or 1-800-737-4473 for information about medical equipment, supplies and services.
- Call your local American Legion, VFW or Lions Club. They often have equipment you can borrow if you are a member.
- Call your local pharmacy to see what selection of equipment that store carries.
- WisTech can connect you with resources for medical equipment in Wisconsin. Visit wisconsinat4all.com to find equipment in your area. You will need to create an account to view available items. Once you have an account, you can buy, rent or get free items from state agencies, private businesses, lending programs or individuals. Each group or individual has different criteria for using their equipment. Contact information is listed for each item.

Grocery delivery

■ **Twin Cities Metro Area Meals on Wheels**

Volunteers deliver ready-to-eat meals to homes in most of the Minneapolis and St. Paul metro area. You can sign up for short- or long-term meal delivery if you are recovering from surgery or illness. The price is based on your need. Call 612-623-3363 or visit meals-on-wheels.com for more information or to sign up for this service.

■ **Home-delivered Meals (Meals on Wheels)**

Wisconsin's Elderly Nutrition Program offers meals to anyone age 60 and older. Meals can be delivered to your door Monday through Friday. Visit gwaar.org to learn more about home-delivered meals. Click *For Seniors and Families* and then *Elderly Nutrition Program*. Select *Contact someone* to find your local agency and its contact information.

- Many grocery stores and organizations offer services that will deliver healthful meals to your home. Ask a member of your health care team for more information.

Websites

Visit:

- **allinahealth.org**
for information about health care and Allina Health facilities or services
- **asahq.org**
for American Society of Anesthesiologists information
- **aaos.org**
for American Academy of Orthopaedic Surgeons information
- **nccaom.org**
for acupuncture information from the National Certification Commission of Acupuncture and Oriental Medicine
- **nccam.nih.gov**
for complementary therapy information from the National Center for Complementary and Alternative Medicine, National Institutes of Health
- **recoversex.com**
for information about resuming sexual activity after surgery.

Notes

My Medicine List

Fold this form and keep it with you

Name:	Date of Birth:	Allergic To: <i>(Describe reaction)</i>
Emergency Contact/Phone numbers:		
Doctor(s):		
Pharmacies, other sources:		

Immunization Record <i>(Record the date/year of last dose taken)</i>		
Pneumonia vaccine:	Flu vaccine(s):	Other:
Tetanus:	Hepatitis vaccine:	

List all medicines you are currently taking. Include prescriptions (examples: pills, inhalers, creams, shots), over-the-counter medications (examples: aspirin, antacids) and herbals (examples: ginseng, ginkgo). Include medications taken as needed (example: nitroglycerin, inhalers).

START DATE	NAME OF MEDICATION	DOSE	DIRECTIONS <i>(How do you take it? When? How often?)</i>	DATE STOPPED	NOTES <i>(Reason for taking?)</i>

Directions for My Medicine List

1. ALWAYS KEEP THIS FORM WITH YOU. You may want to fold it and keep it in your wallet along with your driver's license. Then it will be available in case of an emergency.
2. Write down all of the medicines you are taking and list all of your allergies. Add information on medicines taken in clinics, hospitals and other health care settings — as well as at home.
3. Take this form with you on all visits to your clinic, pharmacy, hospital, physician, or other providers.
4. WRITE DOWN ALL CHANGES MADE TO YOUR MEDICINES on this form. When you stop taking a certain medicine, write the date it was stopped. If help is needed, ask your doctor, nurse, pharmacist, or family member to help you keep it up-to-date.
5. In the "Notes" column, write down why you are taking the medicine (Examples: high blood pressure, high blood sugar, high cholesterol).
6. When you are discharged from the hospital, someone will talk with you about which medicines to take and which medicines to stop taking. Since many changes are often made after a hospital stay, a new list may be filled out. When you return to your doctor, take your list with you. This will keep everyone up-to-date on your medicines.

How does this form help you?

- This form helps you and your family members remember all of the medicines you are taking.
- It provides your doctors and other providers with a current list of ALL of your medicines. They need to know the herbals, vitamins, and over-the-counter medicines you take!
- With this information, doctors and other providers can prevent potential health problems, triggered by how different medicines interact.



For copies of the My Medicine List and a brochure with more tips, visit the Minnesota Alliance for Patient Safety's Web site at www.mnpatientsafety.org or call (651) 641-1121.

Get better communication and faster answers online with your Allina Health account.

Health is a journey that happens beyond the walls of your clinic or hospital and we will be there to help you – whether it's a question that pops into your head at midnight or recalling the date of your last tetanus shot. When you sign up for an Allina Health account online, you get better communication with your clinic, hospital and provider; faster answers and your (and your loved one's) health information organized and at your fingertips anytime.



Sign up for your account at allinahealth.org

**Availability varies by location. Ask your clinic or hospital if this service is available.*

S410726A 162301 1016 ©2016 ALLINA HEALTH SYSTEM. TM – A TRADEMARK OF ALLINA HEALTH SYSTEM.

Allina Health 

Your account is a free service of Allina Health

Nondiscrimination in Health Programs and Activities

Affordable Care Act – Section 1557

Allina Health complies with applicable federal civil rights laws and does not discriminate on the basis of race, color, national origin, age, disability, gender identity or sex. Allina Health does not exclude people or treat them differently because of race, color, national origin, age, disability, gender identity or sex.

Allina Health:

- provides free aids and services to people with disabilities to communicate effectively with us, such as:
 - ◊ qualified sign language interpreters, and
 - ◊ written information in other formats (large print, audio, accessible electronic formats, other formats)
- provides free language services to people whose primary language is not English, such as:
 - ◊ qualified interpreters, and
 - ◊ information written in other languages.

If you need these services, ask a member of your care team.

If you believe that Allina Health has failed to provide these services or discriminated in another way on the basis of race, color, national origin, age, disability, gender identity or sex, you can file a grievance with:

Allina Health Grievance Coordinator
P.O. Box 43
Minneapolis, MN 55440-0043
Phone: 612-262-0900
Fax: 612-262-4370
GrievanceCoordinator@allina.com

You can file a grievance in person or by mail, fax or email. If you need help filing a grievance, the Allina Health Grievance Coordinator can help you.

You can also file a civil rights complaint with the U.S. Department of Health and Human Services, Office for Civil Rights, electronically through the Office for Civil Rights Complaint Portal, available at <https://ocrportal.hhs.gov/ocr/portal/lobby.jsf>, or by mail or phone at:

U.S. Department of Health and Human Services
200 Independence Avenue, SW Room 509F, HHH Building
Washington, D.C. 20201
1-800-368-1019, 800-537-7697 (TDD)

Complaint forms are available at <http://www.hhs.gov/ocr/office/file/index.html>.



- English: ATTENTION: If you speak English, language assistance services, free of charge, are available to you. Call 1-877-506-4595.
- Spanish: ATENCIÓN: Si habla español, tiene a su disposición servicios gratuitos de asistencia lingüística. Llame al 1-877-506-4595.
- Hmong: LUS CEEV: Yog tias koj hais lus Hmoob, cov kev pab txog lus, muaj kev pab dawb rau koj. Hu rau 1-877-506-4595.
- Somali: LA SOCO: Haddii aad ku hadashid af Sswoomaali, adeegyo gargaar luqad, oo bilaash ah, ayaa lagu heli karaa. Wac 1-877-506-4595.
- Chinese: 注意：如果您使用繁體中文，您可以免費獲得語言援助服務。請致電 1-877-506-4595.
- German: ACHTUNG: Wenn Sie Deutsch sprechen, stehen Ihnen kostenlos sprachliche Hilfsdienstleistungen zur Verfügung. Rufnummer: 1-877-506-4595.
- Arabic: ملحوظة: إذا كنت تتحدث انكر اللغة، فإن خدمات المساعدة اللغوية تتوافر لك بالمجان. اتصل برقم 1-877-506-4595.
- Russian: ВНИМАНИЕ: Если вы говорите на русском языке, то вам доступны бесплатные услуги перевода. Звоните 1-877-506-4595.
- Korean: 주의: 한국어를 사용하시는 경우, 언어 지원 서비스를 무료로 이용하실 수 있습니다. 1-877-506-4595 번으로 전화해 주십시오.
- Vietnamese: CHÚ Ý: Nếu bạn nói Tiếng Việt, có các dịch vụ hỗ trợ ngôn ngữ miễn phí dành cho bạn. Gọi số 1-877-506-4595.
- Pennsylvanian Dutch: Wann du [Deutsch (Pennsylvania German/Dutch)] schwetzscht, kannscht du mitaus Koschte ebber gricke, ass dihr helft mit die englisch Schprooch. Ruf selli Nummer uff: Call 1-877-506-4595.
- Laotian: ໂປດຊາບ: ຖ້າວ່າ ທ່ານເວົ້າພາສາ ລາວ, ການບໍລິການຊ່ວຍເຫຼືອດ້ານພາສາ, ໂດຍບໍ່ເສັຽຄ່າ, ຄວນມີພ້ອມໃຫ້ທ່ານ. ໂທ 1-877-506-4595.
- French: ATTENTION: Si vous parlez français, des services d'aide linguistique vous sont proposés gratuitement. Appelez le 1-877-506-4595.
- Polish: UWAGA: Jeżeli mówisz po polsku, możesz skorzystać z bezpłatnej pomocy językowej. Zadzwoń pod numer 1-877-506-4595.
- Hindi: ध्यान दें: यदि आप हिंदी बोलते हैं तो आपके लिए मुफ्त में भाषा सहायता सेवाएं उपलब्ध हैं। 1-877-506-4595 पर कॉल करें।
- Albanian: KUJDES: Nëse flitni shqip, për ju ka në dispozicion shërbime të asistencës gjuhësore, pa pagesë. Telefononi në 1-877-506-4595.
- Tagalog: PAUNAWA: Kung nagsasalita ka ng Tagalog, maaari kang gumamit ng mga serbisyo ng tulong sa wika nang walang bayad. Tumawag sa 1-877-506-4595.
- Cushite: XIYYEEFFANNA: Afaan dubbattu Oroomiffa, tajaajila gargaarsa afaanii, kanfaltiidhaan ala, ni argama. Bilbilaa 1-877-506-4595.
- Amharic: ማሳሰቢያ: የሚናገሩት ቋንቋ አማርኛ ከሆነ የትርጉም እርዳታ ድርጅቶቻችን በነጻ ሊያገለግሉት ተዘጋጅተዋል። ወደ ሚከተለው ቁጥር ይደውሉ፡ 1-877-506-4595.
- Karen: ဟံသုဂ်ဟံသး- နမုာ်ကတိၤ ကညီ ကျိာ်အသိ, နမၤန့ၢ် ကျိာ်အတၢ်မၤစၢၤလၢ တလၢာ်ဘျုးလၢာ်စ့ၤ နီတမံၤဘျုးသ့န့ၢ်လီၤ. ကိး 1-877-506-4595.
- Mon Khmer: ប្រយ័ត្ន៖ បើសិនជាអ្នកនិយាយ ភាសាខ្មែរ, សេវាជំនួយផ្នែកភាសា ដោយមិនគិតថ្លៃ គឺអាចមានសំរាប់បម្រើអ្នក។ ចូរ ទូរស័ព្ទ 1-877-506-4595។



allinahealth.org