

Shoulder Replacement Surgery



Allina Health

Shoulder Replacement Surgery

Second edition

Developed by Allina Health.

© 2021 Allina Health System

The publisher believes that information in this manual was accurate at the time the manual was published. However, because of the rapidly changing state of scientific and medical knowledge, some of the facts and recommendations in the manual may be out-of-date by the time you read it. Your health care provider is the best source for current information and medical advice in your particular situation.

All rights reserved. No part of this book may be reproduced in any form or by any means, electronic or mechanical, including photocopying, without permission in writing from the publisher.

Disclaimer

This publication is for general information only and is not intended to provide specific advice or recommendations for any individual. The information it contains cannot be used to diagnose medical conditions or prescribe treatment. The information provided is designed to support, not replace, the relationship that exists between a patient and his/her existing physician.

For specific information about your health condition, please contact your health care provider.





Table of Contents

Chapter 1: Welcome

Welcome	7
Your Health Care Team	7

Chapter 2: Understanding Your Shoulder and Surgery

The Healthy Shoulder	11
The Shoulder With Arthritis	12
Total Shoulder Replacement	13
Partial Shoulder Replacement (Hemiarthroplasty)	14
Reverse Shoulder Replacement	15

Chapter 3: Before Surgery

Your Health History and Physical Exam	19
Insurance Coverage	20
Determining Your Health Insurance Coverage	21
*Diabetes	22
*Blood Levels Before Surgery	22
*Quit Tobacco For Your Surgery	23

Chapter 4: Preparing for Your Surgery

Preparing for Your Needs After Surgery	29
Breathing Exercises (Respiratory Exercises)	30
Preparing Your Home for Your Needs After Surgery	31
Arrange for Help With Household Tasks.....	32
What to Bring for Your Hospital Stay	33
The Day Before Surgery	34
*Cleansing Your Skin for Surgery	34
Food and Liquid Directions Before Your Surgery	37
The Morning of Surgery	37

Chapter 5: Surgery, Hospital Stay and Beyond

What to Expect the Day of Surgery	41
Anesthesia: What You Need to Know	42
How to Manage Your Pain After Surgery	44
What to Expect After Surgery	47
Your Care Plan	48
Commonly Asked Questions	51
Pain Medicine: What You Need to Know.....	56
Anti-inflammatory Medicines	57
How to Use an Incentive Spirometer	58
Nutrition: What You Need to Know	59
*Restrictions to Follow After Your Surgery	62
*Mobility Guidelines	63
*'Box of Safety'	64
Self-care Guidelines.....	65
Home Exercise Program	67

Chapter 6: Resources

Medical Equipment	73
Community Resource Directory	75
Worksheet: My Medicine List	77

***What To Read Before Surgery**

Here are the most important sections of this book to read before your surgery:

Chapter 3:

- Diabetes (page 22)
- Blood Levels Before Surgery (page 22)
- Quit Tobacco For Your Surgery (page 23)

Chapter 4:

- Cleansing Your Skin for Surgery (page 34)

Chapter 5:

- Restrictions to Follow After Your Surgery (page 62)
- Mobility Guidelines (page 63)
- 'Box of Safety' (page 64)

Chapter 1:

Welcome

In This Chapter:

- Welcome
- Your Health Care Team



Chapter 1: Welcome

Did You Know?

Your **care circle** is your family, friends and others close to you. This term will be used throughout this book.

How do you make your surgery a positive and meaningful experience? Many patients and their **care circles** find it helpful to learn as much as they can before surgery.

This book was created to help you prepare for surgery and guide you through your recovery. The information is not meant to replace advice you receive from your health care team.

Please try to read the entire book before your surgery. Read it at your own pace and write your questions in the margins.

Bring this book with you when you come to the hospital for your surgery. Your health care team will work with you and your care circle to create a recovery plan that is right for you. They will be available to answer any questions you have.

Your health care team looks forward to caring for you!

Your Health Care Team

As you prepare for your shoulder surgery, hospital stay and recovery, your health care team will work with your surgeon to help you along your journey. Members of your health care team may include doctors, doctor (physician) assistants, nurses, nursing assistants, social workers, case managers, and physical and occupational therapists.

You may also be visited by a home health aide, dietitian, respiratory therapist or chaplain.



Chapter 2:

Understanding Your Shoulder and Surgery

In This Chapter:

- The Healthy Shoulder
- The Shoulder With Arthritis
- Total Shoulder Replacement
- Partial Shoulder Replacement (Hemiarthroplasty)
- Reverse Shoulder Replacement



Chapter 2: Understanding Your Shoulder and Surgery

The Healthy Shoulder

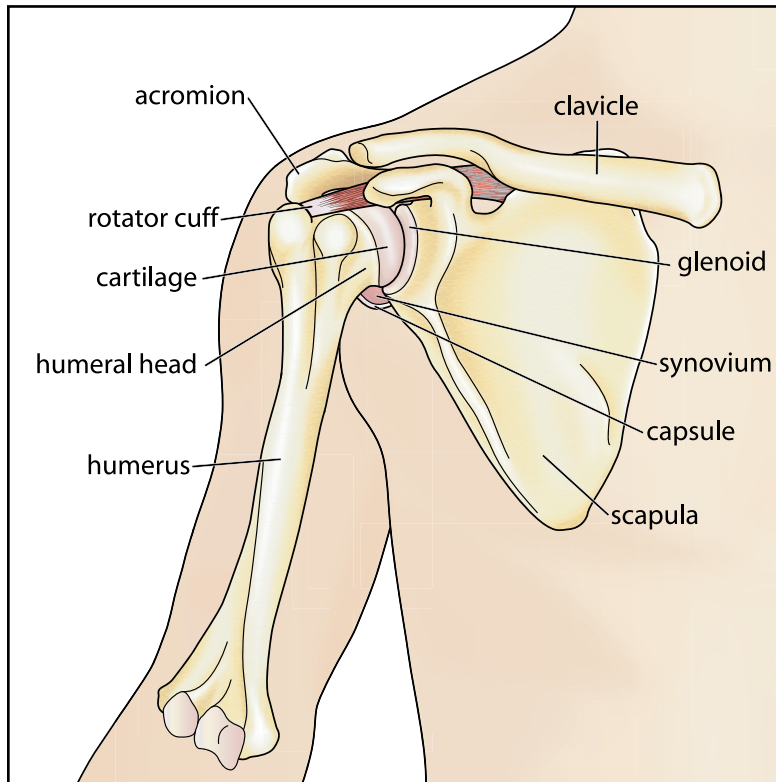

© Allina Health System

Your shoulder is a ball and socket joint with cartilage.

Your shoulder is one of the most mobile joints in your body. This flexibility allows you to move your arm in many positions: to the front, above, to the side and behind your body.

Your shoulder has a lot of flexibility because it is a ball and socket joint. It is made up of three bones:

- upper arm bone (humerus)
- shoulder blade (scapula)
- collar bone (clavicle).

The ball at the top end of the arm bone fits into the small socket (glenoid) of the shoulder blade. This forms the shoulder joint (glenohumeral joint).

The ball and socket are covered with a smooth surface called articular cartilage. This surface allows the smooth motion of the shoulder joint.

The shoulder joint is also made up of ligaments, muscles and tendons.

- The **joint capsule** is a group of ligaments. It surrounds the shoulder joint. The joint capsule allows a wide range of motion and helps hold the ball in the socket.
- The **rotator cuff** is a group of four muscles and tendons that attach the ball to the socket. The muscles of the rotator cuff surround the shoulder joint and sit just outside of the joint capsule.

The muscles attached to the rotator cuff help you to lift and rotate your arm, reach overhead, and take part in activities such as throwing or swimming.

- The **bursa** is a sac-like membrane found on top of the rotator cuff. It cushions and helps lubricate the motion between the rotator cuff and surrounding bones.

The Shoulder With Arthritis

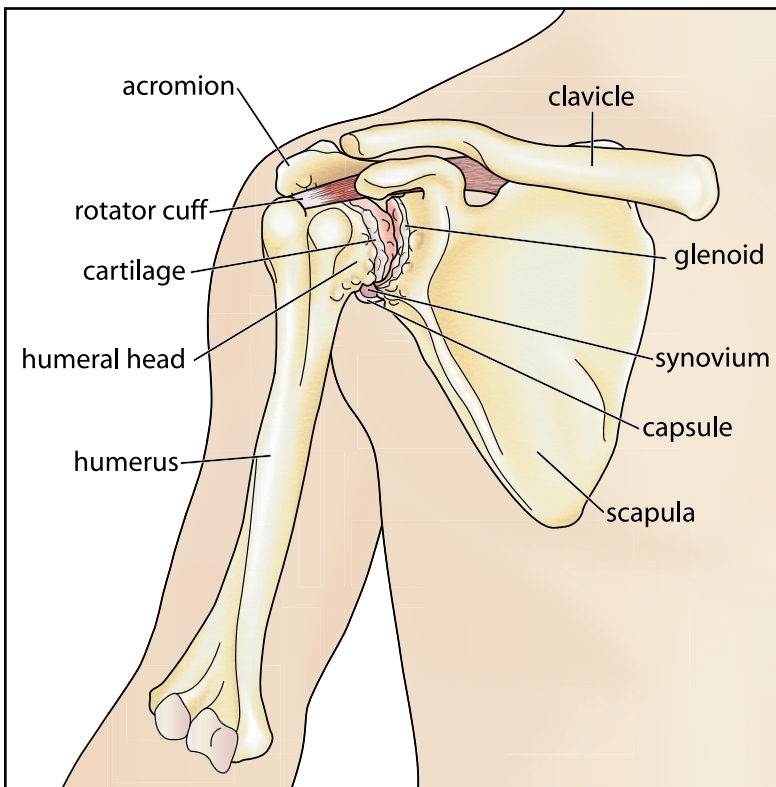

© Allina Health System

Arthritis affects the cartilage in the ball and socket.

Arthritis is a common cause of shoulder joint pain and loss.

“Arthritis” is a name used to describe a number of diseases that affects joints. Arthritic joints suffer from stiffness, pain and swelling.

In an arthritic joint, the cartilage is worn away from the ball and socket. This causes the bones to rub together, which causes pain and loss of motion.

Shoulder arthritis develops slowly. You may feel pain, stiffness and loss of motion over many years.

You can help control symptoms by:

- changing your activity
- taking medicines or having cortisone shots to decrease inflammation (swelling)
- going to physical therapy.

When treatments no longer help, you may want to think about a shoulder replacement.

A shoulder replacement is an option to relieve the pain from arthritis and restore your range of motion. There are three different types surgery:

- **total shoulder replacement:**
This surgery replaces both the ball and the socket.
- **partial shoulder replacement (hemiarthroplasty):**
This surgery replaces only the ball of the joint.
- **reverse shoulder replacement:**
This surgery replaces both the ball and the socket in a way that allows the shoulder to move even without a healthy rotator cuff.

Total Shoulder Replacement



© Allina Health System

An X-ray shows the artificial joint.

Total shoulder replacement replaces the ball and socket with an artificial joint (prosthesis).

The prosthesis has two parts:

- artificial ball (also called a “humeral component”)
- artificial socket (also called a “glenoid component”).

The prosthesis comes in many different sizes.

This allows your surgeon to use the right size for your body. With a standard total shoulder replacement, the rotator cuff is left intact.

This is important because a healthy rotator cuff helps this type of prosthesis work well.

The artificial ball is made of a metal (usually cobalt-chromium based). It is important to tell your health care team if you have a nickel allergy.

The ball is attached to a stem that fits into the upper arm bone. The stem attached to the artificial ball is coated with a special surface that bonds to the surrounding bone. This bond removes the need to use bone cement. It is possible for bone cement to still be used if you have rheumatoid arthritis or very poor bone quality.

The artificial socket is made of a thick, wear-resistant plastic (polyethylene). It is attached to a small stem that fits inside the bone of the socket. The artificial socket is held in place with bone cement. There are some newer designs that have special metal posts that bond to the surrounding bone without cement.

Your surgeon will make the best choice for your shoulder.

Partial Shoulder Replacement (Hemiarthroplasty)

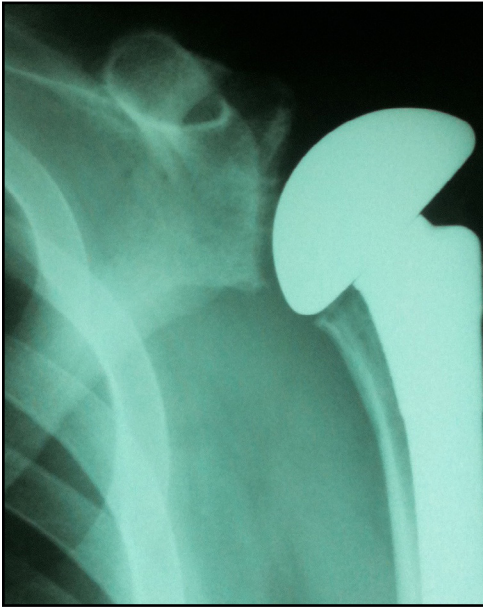

© Allina Health System

An X-ray shows the artificial joint.

Depending on the damage to your shoulder, your surgeon may choose to replace just the ball portion of the shoulder joint. This procedure is called a partial shoulder replacement (hemiarthroplasty).

A partial shoulder replacement may be done if:

- certain types of fractures affect only the ball
- severe bone loss affects the socket and prevents an artificial socket from being used.

Reverse Shoulder Replacement

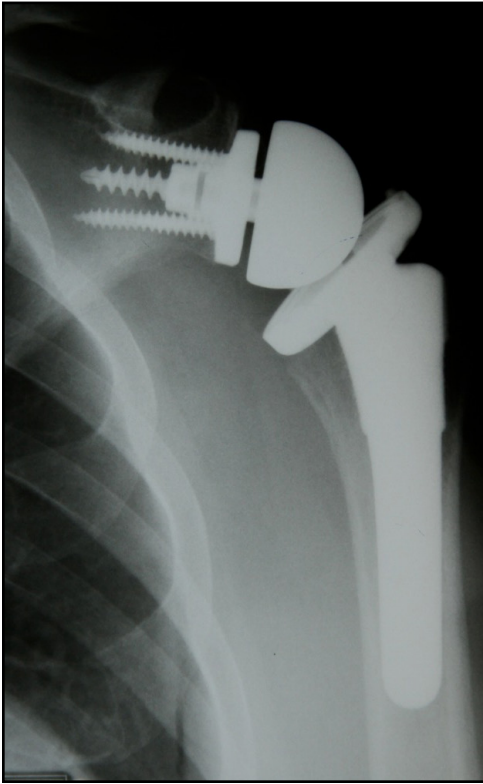

© Allina Health System

An X-ray shows the artificial joint.

Reverse shoulder replacement is for people who have advanced shoulder arthritis and whose rotator cuff is either torn beyond repair or does not work for some other reason.

Most people who get this type of replacement are age 65 years or older, have a lot of pain, and little or no range of motion. This type of shoulder replacement is not right for young or physically active people.

If the rotator cuff tendons have been torn for a long period of time, the ball can move up in the socket. This will change how the shoulder works and also cause arthritis, pain and loss of motion. This special type of shoulder arthritis is known as “rotator cuff tear arthropathy.”

Reverse shoulder replacement has a socket where the ball is normally located and a ball where the socket is normally located. This design will make the shoulder become more stable and provides support even without a rotator cuff.



Chapter 3:

Before Surgery

In This Chapter:

- Your Health History and Physical Exam
- Insurance Coverage
- Determining Your Health Insurance Coverage
- Diabetes
- Blood Levels Before Surgery
- Quit Tobacco For Your Surgery



Chapter 3: Before Surgery

Your Health History and Physical Exam

Important

Your health history and physical exam needs to be done within 30 days before your surgery.

It is recommended to have the exam done 14 to 30 days before surgery.

Your primary care provider should do a health history and physical exam before your surgery. Call your primary care provider to schedule your appointment.

During the exam, your primary care provider will:

- evaluate your current health status
- review and perform any tests needed before surgery
- make sure you are ready for surgery.

If you take any medicines, make sure your primary care provider gives you instructions for the following:

- taking your medicines the morning of surgery
- stopping any prescription medicines before your surgery
- stopping any over-the-counter medicines before your surgery, including herbal medicines.

If you are having your surgery at Abbott Northwestern Hospital

You may be referred to the Abbott Northwestern Hospital Preoperative Clinic. Your surgeon will help you decide if you need this appointment.

If your surgeon refers you to the Preoperative Clinic, please call 612-863-5100 to make your appointment. This appointment will be within 7 to 14 days before your surgery.

If your surgery is scheduled in a shorter amount of time, your clinic appointment may be less than 7 to 14 days before your surgery.

During this appointment, the clinic staff will:

- go over information on safety during your hospital stay
- create your plan of care
- give you pre-surgery instructions about activities on the day of surgery.

Insurance Coverage

Health care benefits change and differ from plan to plan and provider to provider. It is important for you to understand your health care benefits before your surgery.

Now is a good time to call your insurance provider and find out exactly what is and is not covered under your plan, and how much you have to pay yourself.

Use the worksheet on the next page to help you determine your insurance coverage.

Determining Your Health Insurance Coverage

Questions to ask your insurance provider before your hospital stay

Insurance coverage for shoulder surgery is different from plan to plan. You need to know what your health plan covers. To learn about your specific coverage, call your insurance provider at least 2 weeks before your surgery. Look for the telephone number on your membership card. Use this worksheet as a guide to help you get a clear idea of your coverage.

Insurance provider phone number: _____

Policy number: _____

Date/Time of call: _____ Person spoken to: _____

1. I am scheduled for surgery. Does my hospital stay need to be pre-approved? yes no

If yes, who should pre-approve my hospital stay? _____

What do I need to do to receive the pre-approval? _____

2. Will more hospital days be covered if there are problems (complications)? yes no

3. If I need medical equipment, am I pre-approved for it? yes no

Do I have to get the medical equipment from a specific source? yes no

If yes, from whom? _____

Do I need a prescription for the equipment? yes no

4. If I cannot return to my normal home life right after discharge, do I have benefits for rehabilitation and physical therapy? yes no

Using the table below, review the possible needs and financial concerns with your insurance provider. Ask specific questions to help you get a clear idea of your coverage. Be prepared to share this information with your health care team.

Type	Amount insurance pays	My co-pay	Deductible
Short-term rehab*			
Home health care			
Outpatient therapy			
After-surgery medicines			
Medical equipment (pages 73 to 74)			
Transportation** (leaving the hospital)			
Other			

*Short-term rehab is also referred to as transitional care. It takes place in a skilled nursing facility such as a transitional care center or transitional care unit (TCU).

**Transportation services are usually not covered by insurance companies. Plan ahead and arrange for a member of your care circle to drive you home in a comfortable vehicle after you leave the hospital.

Diabetes

If you have diabetes, it is important to have good blood glucose levels before and after surgery. This will help you heal better after surgery and lower your risk of infection.

Talk with your health care provider who manages your diabetes about having good blood glucose levels before your surgery. It is recommended for you to have an A1c level lower than 7.5 percent within 3 months before your surgery.

If your A1c level is 7.5 percent or higher, your surgery may be rescheduled until your blood glucose level is under control.

The stress of surgery can sometimes increase your blood glucose level after surgery. You may be given insulin to control your blood glucose while you are in the hospital. If you take diabetes pills, you will usually start taking them again when you leave the hospital. Follow any instructions your health care provider who manages your diabetes gives you.

Blood Levels Before Surgery

Did You Know?

Hemoglobin is the most important part of a red blood cell. The protein carries oxygen from your lungs to your tissues. Hemoglobin also takes carbon dioxide from the tissues to the lungs. You breathe out the carbon dioxide when you exhale.

Tip

Talk with your surgeon about the risks with blood management.

It is important to have normal blood (hemoglobin) levels before your surgery. This will help you tolerate surgery better and lower your risk of needing a blood transfusion while you are in the hospital. The need for a blood transfusion after shoulder replacement surgery is rare.

Talk with your surgeon about your blood levels. If they are low before surgery, your surgery will need to be rescheduled. This will give your primary care provider time to find out why they are low and give you any treatments needed to get your blood levels back to normal.

After surgery, your blood levels may be low. This is normal. It may take a few months for your blood levels to go back to normal. You and your health care team will work together to find the best way to make sure your blood levels return to normal after surgery. Iron and vitamin C are common supplements used to help blood levels go back to normal.

Quit Tobacco for Your Surgery

Did You Know?

Tobacco products contain more than 7,000 chemicals. More than 70 are known to cause cancer.

Important

Secondhand smoke causes as much damage to healing as if you were smoking.

If you live with someone who smokes, ask him or her to smoke outside for at least the time of your recovery.

Tobacco and surgery risks

Tobacco products include cigarettes, electronic nicotine delivery systems (ENDS, includes e-cigarettes and JUUL®), smokeless tobacco (dip or chew), cigars, hookahs and pipes.

Using tobacco increases your risk of the following during and after surgery:

- heart problems
- lung problems (complications) such as pneumonia
- infections such as infections of your surgery site (incision)
- blood clots
- slower healing of your surgery site
- higher levels of pain and more problems with pain control.

Tobacco use keeps oxygen from reaching your surgery site and it can increase your recovery time.

Benefits of quitting

- Research shows that quitting 4 weeks before surgery can reduce any problems after surgery up to 30 percent.
- People who quit smoking report having better pain control.
- Your body responds quickly to quitting:
 - **8 hours:** the carbon monoxide level in your blood drops to normal. The oxygen level in your blood increases to normal.
 - **48 hours:** Nerve endings start to grow again.
 - **2 weeks:** Your circulation improves and your lung function increases. (Source: World Health Organization)

When you should quit

Ideally, you should quit as soon as possible. Research shows that:

- the harmful effects from cigarettes begin to go down about 12 hours after your last cigarette smoked
- at least 8 weeks without cigarettes is the best way to reduce problems almost as low as people who do not smoke.

The American College of Surgeons recommends at least 4 weeks without cigarettes.

Did You Know?

Using your surgery as a motivator to quit tobacco increases your success rate of quitting for good.

You should not use tobacco the day of surgery up to 1 week after your surgery. Your doctor may tell you when to quit before your surgery.

If you quit for surgery, you double the chance of staying off cigarettes for good. Many people report they have no cravings while in the hospital.

Not ready to quit? Consider taking a break!

If quitting tobacco makes you feel nervous and seems overwhelming, consider taking a break or a vacation from tobacco use.

- You will get the physical benefits for the period of time that you are not using tobacco.
- You will reduce your risk of problems during surgery and still increase your chances of a smooth recovery after surgery.

If you can, set a goal to stop using tobacco for 1 month after your surgery. This will allow your body to heal the best after your surgery.

Ways to quit or take a break

- abrupt stop (cold turkey)
- nicotine replacement therapy* (gum, lozenge, patch or inhaler)
- medicines (Chantix[®] and Zyban[®])
- behavioral strategies such as calling a friend or going for a walk
- aromatherapy (black pepper oil)
- take a break (vacation) from tobacco.

Any step you take without tobacco is going to help you. Small steps are better than nothing!

***Nicotine replacement therapy (NRT) can nearly double your chances of successfully staying off cigarettes. It works best if you use it with the help of a doctor or counselor. Ask your doctor about using NRT around the time of surgery. Go to quitforsurgery.com to learn more.**



Resources

Allina Health

- Tobacco Intervention Program at Abbott Northwestern Hospital
— 612-863-1648
- Tobacco Intervention Program at Mercy Hospital
— 763-236-8008
- Tobacco Intervention Program at River Falls Area Hospital
— 715-307-6075
- *United Hospital Lung and Sleep Clinic Tobacco Cessation Program
— 651-726-6200
- *Penny George™ Institute for Health and Healing (LiveWell Center) tobacco intervention coaching
— 612-863-5178

Product-specific Resources

- Chantix® GetQuit Support plan
— 1-877-CHANTIX (1-877-242-6849)
— get-quit.com
- financial aid for Chantix® or Nicotrol® inhaler
— 1-866-706-2400
— pfizerrxpathways.com
- Plant Extracts aromatherapy
— 1-877-999-4236

Other

- Quit Partner
— 1-800-QUIT-NOW (1-800-784-8669) or quitpartnermn.com
— American Indian: 1-833-9AI-QUIT or aiquit.com
— Spanish: 1-855-DEJELO-YA (1-855-335-3569) or quitpartnermn.com/es
— Teens: text "Start My Quit" to 1-855-891-9989 or call to talk with a coach
- Minnesota Department of Health
— health.state.mn.us/quit
- online tobacco cessation support
— smokefree.gov
- American Lung Association/Tobacco Quit Line
— 651-227-8014 or 1-800-586-4872
- *Mayo Clinic Nicotine Dependence Center's Residential Treatment Program
— 1-800-344-5984 or 1-507-266-1930

*There may be a cost to you. Check with your insurance provider.



Chapter 4:

Preparing for Surgery

In This Chapter:

- Preparing for Your Needs After Surgery
- Breathing Exercises (Respiratory Exercises)
- Preparing Your Home for Your Needs After Surgery
- Arrange for Help With Household Tasks
- What to Bring for Your Hospital Stay
- The Day Before Surgery
- Cleansing Your Skin for Surgery
- Food and Liquid Directions Before Your Surgery
- The Morning of Surgery



Chapter 4: Preparing for Surgery

Preparing for Your Needs After Surgery

Preparing for your needs after surgery before you have your surgery will help your recovery go much better.

After shoulder replacement surgery, most patients are able to go home the day after surgery.

If you feel you cannot return home right away after surgery, please let your surgeon and health care team know right away. Some patients benefit from a short stay in a transitional care unit (TCU) or short-term rehabilitation center. If this is needed, your health care team will arrange for these services before you leave the hospital.

Breathing Exercises (Respiratory Exercises)

Tip

An incentive spirometer is a hand-held breathing exercise device to help you inflate your lungs after surgery. This will help keep your lungs healthy after surgery.

You can read about how to use an incentive spirometer in chapter 5.

Performing respiratory exercises will help you prevent respiratory system problems (complications). Deep breathing, coughing, and incentive spirometer exercises may speed your recovery and lower your risk of lung problems such as pneumonia. Learn the following exercises and practice them every day before your surgery.

Deep breathing

To deep breathe correctly, you must use your abdominal muscles, as well as your chest muscles.

- Breathe in through your nose as deeply as possible.
- Hold your breath for 5 to 10 seconds.
- Let your breath out through your mouth, slowly and completely. As you breathe with pursed lips (like blowing out a candle), your stomach should be going in. Exhale twice as long as you inhale.
- Rest and then repeat these steps with 10 repetitions.

Coughing

To help you cough:

- Take a slow deep breath. Breathe in through your nose and concentrate on fully expanding your chest.
- Breathe out through your mouth and concentrate on feeling your chest sink downward and inward.
- Take a second breath in the same manner.
- Take a third breath. This time hold your breath for a moment, then cough vigorously. As you cough, concentrate on forcing all the air out of your chest.
- Repeat this exercise two more times.

Preparing Your Home for Your Needs After Surgery

To help prepare your home for your recovery, use the following guidelines. Check each item box as you complete that item.

Outside your home

- Move items you use a lot in the garage or workshop to tabletop-height surfaces or to middle shelves.
- Check stair railings to make sure they are secure. It is best if all stairs have railings.
- Be aware of uneven ground around your home and in your yard.
- Be sure your driveway and walking paths are uncluttered.

Inside your home

- Have clear pathways and remove clutter around your home.
- Pick up all throw rugs in your walking or standing path. Consider using double-sided tape to secure carpet edges.
- Check stair railings to make sure they are secure. It is best if all stairs have railings.
- Make your phone accessible to your main sitting area and bed. Cordless phones or cell phones are helpful. Carry a cordless phone or cell phone when you are home alone in case of an emergency.

Living room

- Move low-height tables away from the couch and chairs.
- Pick out a chair to sit in when you come home.
 - A good chair is firm with arms.
 - The seat height of your chair should be at the level of the back of your knee or higher.
 - Do not sit in overstuffed chairs and sofas, or chairs with wheels or gliders. A firm chair with a straight backrest is best.

Kitchen

- Move items you use a lot in the kitchen to tabletop-height surfaces or to middle shelves.
- Prepare and freeze a few meals before your surgery.

Bedroom

- Move items you use a lot to tabletop-height surfaces or to middle shelves.

Bathroom

- Move items you use a lot in the bathroom to tabletop-height surfaces or to middle shelves.
- Consider putting grab bars in the bathtub, shower or both. Also consider other key areas for grab bars such as by the toilet. (Grab bars should be installed into wall studs to ensure they are secure. Using a towel bar or rack for a grab bar is not a safe option.)
- Apply adhesive slip strips or a bath mat to the tub or shower floor.
- Consider a hand-held shower head.
- Consider using a soap dispenser with liquid soap in the bathtub or shower rather than using hand-held soap. Otherwise, place a bar of soap in a nylon stocking and tie it onto a soap dish.

Arrange for Help With Household Tasks

Make plans to have someone help with the following household tasks. Check off each box once you have arranged for help with that task.

- Find someone to do your yard work and snow removal.
- Have your paper and mail delivered to your door instead of curbside.
- Have someone drive you to the grocery store (or ask him or her to do your shopping for you), community events, family activities and appointments.
- Find someone to help care for your children or pets if needed.
- Find someone to do your house cleaning, vacuuming and bed changing.

What to Bring for Your Hospital Stay

Important

Please do not bring any of the following:

- valuables
- medicines (pills, inhalers)
- large amounts of money
- jewelry (wedding ring).

Reminder

Please have a member of your care circle:

- bring your belongings into the hospital after your surgery is done and you have been assigned a room number
- lay out the clothes you will wear the day after surgery.

Please bring the following to the hospital.

- this education book
- a current list of your medicines (The “My Medicine List” is on page 77 for you to fill out.)
- a copy of your health care directive (if you have one)
- driver’s license or photo ID
- your insurance information (insurance card, Medicare card, work compensation information or all three)
- personal care items such as a toothbrush, toothpaste, denture cleaner, comb, skin care products, deodorant, make-up and shaving kit
- loose-fitting tops, bottoms or button-up shirts. You may get dressed in the morning in your own clothes.
- clothing you will wear home, including loose-fitting pants, shirt, underwear and socks
- flat shoes or athletic shoes (comfortable, supportive with nonslip soles)
- glasses or contacts (if you wear them) and storage containers
- hearing aides (if you wear them), storage container and extra batteries
- CPAP machine (if you use one)
- reading materials (All rooms have a television and telephone.)
- phone numbers of family and friends
- blank check or credit card. Ask a member of your care circle to bring this to you if you need to purchase any equipment to take home.

The Day Before Surgery

- Tell your surgeon if you have any changes in your health (sore throat, cold, fever, dental problem, urinating problem) or skin condition (rash, abrasions). You may need to schedule your surgery for a later date.
- If you take diabetes medicine, ask the health care provider who is managing your diabetes if you should take your medicine before surgery.
- Bathe or shower using the “Cleansing Your Skin for Your Surgery” instructions on the next pages or as directed by your surgeon.

Cleansing Your Skin for Surgery

Tip

If you cannot wash the surgery area yourself, have a member of your care circle help you.

Before surgery, you have an important role in reducing your risk of infection at the surgery site. You can reduce the number of germs on your skin by gently cleansing your skin with the Sage® 2% Chlorhexidine Gluconate Cloths. **Do not to use these cloths if you have an allergy to chlorhexidine gluconate.**

Important: Do not shave your body below your neck 7 days before your surgery.

The night before surgery, take a bath or shower. Wait 1 to 2 hours. Wipe your skin well with the Sage cloths. They have a special antiseptic solution. Use both of the cloths in each of the three packages.

Important

Do not follow the instructions on the Sage packages when cleansing your skin. Follow the instructions below.

Important

Wash the area with soap and water if your skin starts to itch or burn, or you get a rash. Tell a member of your health care team (when you arrive for surgery) if you have any of these symptoms.

Night before surgery (at least 1 to 2 hours after taking a bath or shower)

- Gather your supplies: two packages of Sage 2% Chlorhexidine Gluconate Cloths, scissors, and clean clothes or sleepwear.
- Open both packages. Remove the cellophane wrapper and throw away. Use scissors to cut open the packages. Cut straight across the top of each package.
- Reach into one of the two open packages. Take out two cloths at one time with the foam holder and put them on a clean surface. Repeat for the second package.
- After you start using the cloths, do not touch your eyes, ears or mouth.

Chlorhexidine wipes warning

Do not use chlorhexidine wipes or liquid if you:

- are sensitive to surgery skin preps
- know you have an allergy to chlorhexidine.

If you notice your skin is irritated while using the chlorhexidine wipes or liquid, remove it gently with a wet washcloth. Tell your pre-surgery nurse you had a reaction so he or she can make a note of your allergy history and tell others on your health care team.

There are rare cases of this product causing a serious allergic reaction. This can occur within minutes of use. **Call 911 if you have any of these:**

- wheezing or difficulty breathing
- swelling of the face
- hives
- severe rash
- shock.

- Follow the skin cleansing steps on the next page.
 - Gently cleanse your skin using a back-and-forth motion.
 - Be sure to completely cover each area. You may need help wiping some areas of your body.

After you gently cleanse each area, let your skin air dry for 1 to 3 minutes. It is normal for your skin to feel tacky or sticky for several minutes after you apply the solution.

- **Do not rinse or rub off the solution.**
- **Do not apply deodorant, perfume, lotions, moisturizers, gels, powders or make-up after cleansing your skin.**
- Throw away the used cloths. Do not flush them down the toilet.
- Wash your hands with warm water and soap.
- Put on clean clothes or sleepwear.
- Put clean sheets on your bed. Make sure pets stay off of your bed to keep it clean.

Tip

Cleanse your skin gently with the cloths.

Skin cleansing steps

- ① Using the first cloth, **wipe your neck and chest.**
- ② Using the second cloth, **wipe both arms.** Start at your shoulder and end at the fingertips. Be sure to wipe well under each arm and in the armpit areas.

Important: Wipe the armpit areas last. Do not wipe the front of your shoulders after wiping the armpit.

- ③ Using the third cloth, **wipe your back.** Start at the base of your neck and end at the buttocks.
- ④ Using the fourth (last) cloth, repeat step 2 to the front of your shoulder.

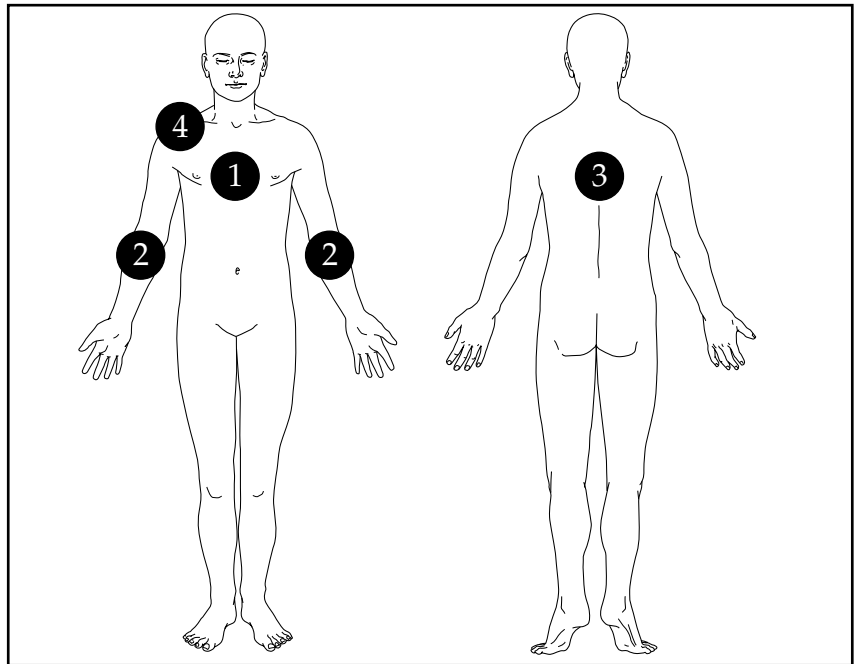

© Allina Health System

The numbered areas in the illustration show where to cleanse your body using each of the cleansing cloths. The numbers in the text above give you more details on how to cleanse your body.

Food and Liquid Directions Before Your Surgery

These directions are based on your scheduled arrival time. Not following these directions could mean your surgery will be delayed or canceled.

Alcohol and tobacco: 24 hours

- Do not drink any alcohol 24 hours before your scheduled arrival time.
- Do not smoke, vape, use chewing tobacco or use any other tobacco products up to 24 hours before your scheduled arrival time.

Solid foods: 8 hours

- Eat up to 8 hours before your scheduled arrival time.
 - Eat light meals such as oatmeal or toast.
 - Do not eat foods that are heavy or high in fat such as meat or fried foods.

Clear liquids: 2 hours

- Drink only clear liquids up to 2 hours before your scheduled arrival time.
 - Drink water, fruit juice without pulp, black coffee, clear pop or tea.
 - Do not have milk, yogurt, energy drinks or alcohol.

Medicines

- Take your medicines as directed with a small sip of water.
 - Talk with your surgeon if you have diabetes or if you take warfarin (Coumadin® or Jantoven®).

The Morning of Surgery

- If you were given instructions by your health care provider to take medicines the morning of your surgery, take them as directed with a small sip of water.
- Do not take a bath or shower the morning of your surgery.
- Put on clean, comfortable clothes to wear to the hospital.
- Arrive at the hospital at least 2 hours before your surgery. Allow extra time for walking, bad weather and traffic.



Chapter 5:

Surgery, Hospital Stay and Beyond

In This Chapter:

- What to Expect the Day of Surgery
- Anesthesia: What You Need to Know
- How to Manage Your Pain After Surgery
- What to Expect After Surgery
- Patient Care Plan
- Commonly Asked Questions
- Pain Medicine: What You Need to Know
- Anti-inflammatory Medicines
- How to Use an Incentive Spirometer
- Nutrition: What You Need to Know
- Restrictions to Follow After Your Surgery
- Mobility Guidelines
- 'Box of Safety'
- Self-care Guidelines
- Home Exercise Program



Chapter 5: Surgery, Hospital Stay and Beyond

What to Expect the Day of Surgery

It is important to arrive for your surgery on time. Your surgery may have to be rescheduled if you arrive late. Please allow extra time for weather, traffic and parking.

When you arrive at the hospital

- Go to the surgery registration area.
- After you check in, you will be directed to the pre-surgery care area.

Pre-surgery care area

- Go to the waiting room.
- You will be brought back to a pre-surgery care suite.
- A nurse will meet with you to complete your care plan.
- After you are settled, the person with you on the day of surgery will be invited back to join you.
- Your nurse will review what you can expect before and after your surgery.
- Your anesthesiologist will also meet with you. Your anesthesiologist and surgeon will work with you to choose the right type of anesthesia for your surgery.
- Your surgeon will visit with you. He or she will mark the surgery site on your body and answer any questions you may have.
- You will be asked to sign a consent form.

Information for your care circle

- While you are in surgery and recovery, your care circle can wait in the surgery waiting room.
- Your surgery time will vary depending on the type of surgery you are having. Your surgeon will talk with your care circle when your surgery is over.

Anesthesia: What You Need to Know

Tip

Talk with your anesthesiologist about the risks with anesthesia.

Anesthesia is a combination of medicines that block the feelings of pain sensation and minimize awareness during surgery. You will receive other pain medicine to give you pain relief during and after surgery.

Before surgery you will meet an anesthesiologist (doctor) and a certified registered nurse anesthetist (CRNA) who will work with the anesthesiologist. The anesthesiologist will review your medical history and talk with you about your anesthesia options. Your choice depends on your surgery, medical and surgical history, and physical condition. The anesthesiologist will talk with you to decide which anesthesia is best for you.

Type	Definition	Benefits	Side effects
General anesthesia	General anesthesia puts you to sleep during surgery. It acts mainly on your brain and nervous system and affects your entire body. You receive it by shot (injection) or by inhaling it. A breathing tube helps you breathe while you are under the anesthesia. You are unconscious during general anesthesia.	General anesthesia may be more appropriate for longer or more involved surgery. It may also be used if the position you will be in during surgery is uncomfortable.	Minor side effects such as sore throat, headache, hoarseness, upset stomach (nausea) and drowsiness are the most common. These side effects usually go away in 1 day. Tell a member of your health care team if you have any of these side effects.
Regional anesthesia (including spinal anesthesia)	Regional anesthesia affects specific nerves which block sensation to a limited area of your body. It is usually given with light sedation, which provides comfort and relieves anxiety while the nerve blocks are placed. You receive it by shot (injection). Spinal anesthesia numbs the lower half of your body for about 3 to 4 hours. You receive an injection between the vertebrae. Epidural anesthesia allows you to receive pain medicine after surgery. A thin plastic tube (catheter) is placed in your spine to allow for extra injections or medicines after surgery.	Less medicine is needed so you wake up quicker with less chance of upset stomach (nausea). Regional anesthesia can be less stressful to your heart and lungs than general anesthesia can be. Regional anesthesia can be used to provide pain relief after surgery.	Minor side effects such as small headaches, itching or trouble urinating are the most common. These side effects usually go away a few days after surgery. Tell a member of your health care team if you have any of these side effects.

Post Anesthesia Care Unit (PACU)

- After surgery, you will be taken to the recovery room or Post Anesthesia Care Unit (PACU).
- Most people stay about 1 to 1 ½ hours in the PACU. Your time in the PACU will depend on your surgery and how fast you recover from the anesthesia.
- Your nurse will monitor your vital signs and help you if you have any side effects from the anesthesia.
- You may have some discomfort and pain when you wake up. Everyone reacts to pain differently. Your nurse will work with you to make you as comfortable as possible.
- You may have a regular pillow or large triangle-shaped foam pillow (abductor pillow) that fits between your legs to keep you from crossing them.
- An X-ray may be taken of your new joint in the PACU.

Orthopedic unit

- When you are fully awake and your medical status is stable, you will be taken to your room in the orthopedic unit where nurses specialized in orthopedic procedures will care for you.
- When you are in your room, it is important to begin:
 - doing ankle pump exercises. This will help to prevent blood clots from forming in your legs.
 - using your incentive spirometer and doing the deep breathing exercises. See page 58 for instructions for how to use your incentive spirometer.

How to Manage Your Pain After Surgery

Important

Having no pain while in the hospital is not realistic, but pain can be controlled.

Your health care team will work closely with you to help manage your pain during your hospital stay and when you return home.

You and your health care team will establish a “pain goal” — the amount of acceptable pain you can tolerate during your hospital stay.

For most people, a pain goal of 3 or 4 out of 10 is an OK pain level that balances pain control with your ability to do physical therapy and daily activities.

Types of pain

Pain can last less than 3 to 6 months (acute), last a long time (chronic) or be severe and intense (breakthrough). Pain can come and go with injury, recovery or illness.

Your right to pain management

You have the right to have your pain managed. Proper treatment of pain is necessary for you to achieve the best results during your recovery.

If you do not think your pain is being treated well, please tell a member of your health care team. He or she will talk with you about your pain and pain management needs.

Pain scale

Using a number scale (0 to 10) to rate your pain will help the health care team members know how severe your pain is and help them make decisions about how to treat it.

Allina Health Pain Assessment Scale

10	Worst Pain You Can Imagine
7-9	Severe Pain Pain keeps you from doing your regular activities. ⑨ Pain is so bad that you can't do any of your regular activities, including talking or sleeping. ⑧ Pain is so intense that you have trouble talking. ⑦ Pain distracts you and limits your ability to sleep.
4-6	Moderate Pain Pain may interfere with your regular activities. ⑥ Pain makes it hard to concentrate. ⑤ You can't ignore the pain but you can still work through some activities. ④ You can ignore the pain at times.
1-3	Mild Pain Pain doesn't interfere with your regular activities. ③ You may notice the pain but you can tolerate it. ② You may feel some twinges of pain. ① You may barely notice the pain.
0	No Pain

Adapted with permission by Dr. Armaan Singh, 2015.

Important

Since you are the only one who knows where and how severe your pain is, you have an important part in managing your pain.

Important

When medicines are used correctly to manage pain, addiction rarely occurs. Talk with your a member of your health care team if you have concerns about this issue.

Your role in managing pain

After surgery, it is common to have some pain. Your nurse will monitor your pain level often and help you manage the pain.

Since you are the only one who knows where and how severe your pain is, you have an important part in managing your pain.

If you have pain, tell a member of your health care team.

All of the following information will help your health care provider prescribe the right medicine and therapy for your pain, and prevent serious side effects (complications). Tell a member of your health care team:

- where you feel pain and how much pain you have (use words to describe how the pain feels)
- what makes your pain better or worse
- what methods of pain control have worked or have not worked well in the past
- if you take pain medicines on a regular basis
- if you have allergies or reactions to pain medicine(s)
- your goals for managing your pain
- what vitamins, herbal and natural products you are taking
- if you smoke
- if you drink more than two alcoholic drinks each day
- if you take illegal (street) drugs
- if you are in a methadone maintenance program.

Treatments for pain

Managing your pain is more than taking prescription (opioid) pain medicine. There are many different types of treatments for pain including:

- medicines
- physical therapy
- heat or cold (ice packs)
- integrative therapies: music, relaxation techniques, massage, aromatherapy
- psychological therapies
- nerve blocks.

Tip

Take pain medicine when pain first begins. If you know your pain may get worse with activity, take your pain medicine before the activity.

Do not wait for pain to get worse before taking medicine. Tablets or pills may take up to 30 minutes to begin working. Timing of when to take medicines is important.

Talk to a member of your health care team about how to time your pain medicines before therapy or activity.

Pain medicine side effects

All medicines have some side effects, but not everyone gets them. When side effects occur, it is usually within a few hours after taking the medicine. Most side effects can be managed and go away in time.

Tell a member of your health care team right away if you have:

- constipation
- sleepiness
- dizziness
- itching, a rash or both
- upset stomach (nausea) and throwing up (vomiting)
- slowed breathing
- trouble concentrating
- forgetfulness
- increased anxiety.

Pain control can help you

The right pain control can help:

- you be more comfortable
- you get back to your normal routine
- you participate more completely in your exercises and therapy
- promote healing.

Before you go home

A member of your health care team will give you instructions for managing your pain at home. Be sure to have written instructions with a health care provider's name and phone number who will manage your pain after you go home.

It is important you follow any instructions you receive for taking pain medicine. Ask a member of your health care team if you need help.

Call the health care provider who prescribed the medicine or your primary care provider if you have concerns or side effects from pain medicine.

What to Expect After Surgery



© Allina Health System

This is the proper position for your immobilizer.

The day of surgery

After you leave the recovery room or PACU, you will be taken to your hospital room. Your family and friends will be able to join you at that time.

You will wear an immobilizer on your shoulder to keep it from moving. You will need to wear your immobilizer all the time except when:

- doing your exercises
- showering or taking a bath
- getting dressed
- eating
- doing tabletop activities such as writing or typing.

The rest of your hospital stay

During the rest of your hospital stay, you will need to:

- turn and change positions in bed with help from your nurse
- be helped to sit in a chair and to walk.

Your health care team will help you get dressed, use the toilet, take a shower or bath, and eat.

You will also learn exercises from a physical therapist to do at home.

Leaving the hospital

In general, most shoulder replacement patients leave the hospital the first day after surgery. Your health care team will work with you to determine discharge and home care needs.

You may leave the hospital if:

- you are eating and drinking without problems
- your incision is healing
- your pain is under control
- you are able to tolerate activities
- you can do the assigned exercises on your own.



Your Care Plan





A smooth and speedy recovery depends on your help and cooperation. Your participation is essential in reaching your goal to return home and prevent problems (complications).

Many wonder how long they will need to stay in the hospital after surgery. In general, most people who have shoulder replacement surgery are able to go home the day after surgery. Your health care team will work with you to determine your discharge and home care needs.

Shoulder Replacement Surgery

In general, this Care Map is what you can expect during your hospital stay of 2 days. Your health care team will make changes unique to your recovery. You will be discharged by _____. You and your nurse will fill this out as you work on discharge planning together.

	Day of Surgery Date: _____	First Day After Surgery Date: _____
Plan for Leaving the Hospital (Discharge) 	<ul style="list-style-type: none"> <input type="checkbox"/> Most patients are able to go home the day after surgery. <input type="checkbox"/> After your stay, you can plan to go: <ul style="list-style-type: none"> <input type="checkbox"/> home <input type="checkbox"/> home with home care services. <input type="checkbox"/> Meet with a social worker if you have needs after your hospital stay. <input type="checkbox"/> Confirm your discharge plan with your nurse. <input type="checkbox"/> Make plans for who will take you home from the hospital. 	<ul style="list-style-type: none"> <input type="checkbox"/> You may leave the hospital if: <ul style="list-style-type: none"> <input type="checkbox"/> you are eating and drinking without problems <input type="checkbox"/> your pain is under control. <input type="checkbox"/> If you have questions after you leave the hospital, call your surgeon.
Comfort  Your pain goal:	<ul style="list-style-type: none"> <input type="checkbox"/> You may receive pain medicine by intravenous (IV) line in your hand or arm. <input type="checkbox"/> You may have pain medicine by mouth if you do not have nausea (upset stomach). <input type="checkbox"/> Ice packs will be used to help control pain. <input type="checkbox"/> Your nurse will ask you often about your pain. <input type="checkbox"/> You may have a nerve block or peripheral nerve catheter to provide numbing medicine. This will help decrease pain near the surgical site and area around it. The feeling of numbness is temporary. 	<ul style="list-style-type: none"> <input type="checkbox"/> You may have pain medicine by mouth if you do not have nausea. <input type="checkbox"/> Ice packs will be used to help control pain. <input type="checkbox"/> Your nurse will ask you often about your pain. <input type="checkbox"/> You will receive education if you are going home with a peripheral nerve catheter or have a nerve block.
Tests, Labs and Procedures	<ul style="list-style-type: none"> <input type="checkbox"/> You may have a wound drain. It will be removed the day after surgery before you leave the hospital. 	<ul style="list-style-type: none"> <input type="checkbox"/> If you have a drain, it will be removed. <input type="checkbox"/> You will have blood tests.

Day of Surgery	First Day After Surgery
<p>Activity</p>  <ul style="list-style-type: none"> <input type="checkbox"/> Your nurse will help you turn and change positions in bed. <input type="checkbox"/> You will wear a sling to support your shoulder. <input type="checkbox"/> You will be helped to sit in a chair and to walk. <input type="checkbox"/> You may wear leg compression devices to prevent blood clots. 	<p>Date: _____</p> <ul style="list-style-type: none"> <input type="checkbox"/> You will wear a sling on your shoulder to keep it from moving. <input type="checkbox"/> You remove the sling to do exercises and shower as directed. <input type="checkbox"/> You will sit in a chair and go for walks. <input type="checkbox"/> You may meet with an occupational therapist and a physical therapist if you have needs. <input type="checkbox"/> You may wear leg compression devices to prevent blood clots.
<p>Food and Drink</p>  <ul style="list-style-type: none"> <input type="checkbox"/> You may have your regular diet if your stomach is not upset. <input type="checkbox"/> Your nurse will show you how to order your prescribed meals using the At Your Request menu. 	<p>Date: _____</p> <ul style="list-style-type: none"> <input type="checkbox"/> You may have your regular diet. <input type="checkbox"/> Order your meals through the At Your Request menu.
<p>Breathing</p>  <ul style="list-style-type: none"> <input type="checkbox"/> Take deep breaths and cough often. <input type="checkbox"/> Use the incentive spirometer as directed. <input type="checkbox"/> An oxygen machine will check the oxygen level in your blood. <input type="checkbox"/> You may receive oxygen. <input type="checkbox"/> If your oxygen levels are OK, your nurse will remove the oxygen from your nose. 	<ul style="list-style-type: none"> <input type="checkbox"/> Take deep breaths and cough often. <input type="checkbox"/> Use the incentive spirometer as directed. <input type="checkbox"/> An oxygen machine will check the oxygen level in your blood.
<p>Bladder and Bowel</p>  <ul style="list-style-type: none"> <input type="checkbox"/> Your nurse will check the amount you urinate. <input type="checkbox"/> You may take medicine to prevent constipation. 	<ul style="list-style-type: none"> <input type="checkbox"/> Your nurse will check the amount you urinate. <input type="checkbox"/> You will take medicine to prevent constipation.

Commonly Asked Questions

When should you call your surgeon or primary care provider?

Call your **surgeon** if you have:

- a temperature of 101.6 F or higher
- problems or signs of infection at your incision site such as:
 - pain
 - swelling
 - redness
 - odor
 - warmth
 - green or yellow discharge
- any change in your ability to move such as new weakness, or not being able to move your arm or leg
- any change in sensation such as new numbness or tingling
- any unusual bruising or bleeding
- severe pain not relieved by medicine, rest or ice
- any problems, questions or concerns related to your surgery.

Call your **primary care provider** if you have:

- feelings of being dizzy or lightheaded
- an upset stomach (nausea) and throwing up (vomiting) that will not stop
- any bowel problems such as constipation or bloody stools
- any problems urinating such as burning, urgency or frequency
- any other problems, questions or concerns.

Call 911 or have someone take you to the nearest hospital Emergency Department if you have any chest pain, trouble breathing or shortness of breath.

What are signs and symptoms of an infection?

Signs and symptoms may include:

- increased redness, swelling or warmth at the incision site
- change in color, amount, odor of drainage
- increased pain in the shoulder
- temperature higher than 101.6 F.

Call your surgeon's office if you have any of the above signs or symptoms.

What are signs and symptoms of a blood clot?

Signs and symptoms may include:

- swelling in one or both arms or legs
- pain or tenderness in one or both arms or legs
- warmth of the skin in the affected leg or arm
- redness or discolored skin in the affected leg or arm.

Call your health care provider if you have any of the above signs or symptoms.

What are signs and symptoms of a pulmonary embolism?

Signs and symptoms may include:

- shortness of breath
- sharp chest pain that may get worse with deep breathing or coughing
- confusion
- sweating
- signs of shock.

Call 911 right away if you have any of the above signs or symptoms.

How do you take care of your incision and change the dressing?

- Follow the instructions your surgeon or nurse gives you on how to take care of your incision and change your dressing.

How soon can you take a bath or shower?

- Do not take a bath until your surgeon says it is OK.
- Keep your incision clean and dry until you see your surgeon at your follow-up appointment.

When can you return to your normal diet?

As soon as you are able, eat well-balanced meals and snacks to help you recover more quickly and to help you feel your best. What you eat after your surgery affects your well-being. You need to eat healthful foods and drink a lot of liquids. See pages 59 to 61 for more information about nutrition.

Important

A pulmonary embolism happens when a blood clot loosens and travels through the bloodstream into the lungs and enters a pulmonary artery.

How do you manage constipation after surgery?

Constipation is common after surgery, especially while you are taking pain medicine and your daily activity level is decreased.

Signs of constipation include:

- fewer number of bowel movements
- small, hard stools that are difficult to pass
- feeling bloated and uncomfortable
- gas
- abdominal cramping

How to prevent constipation

- Drink six to eight 8-ounce glasses of liquids each day. Liquids add moisture to stool, making them easier to pass. Water is your best choice. Caffeine or alcohol can make constipation worse.
- Eat more high-fiber foods such as whole-grain bread, bran cereals, fresh fruit and vegetables.
- Be as active as you can each day. Walking around your house or apartment will help. Follow your health care provider's instructions for exercise.
- Try to have a bowel movement when you feel the urge. Do not ignore the urge. Try to set aside some time after breakfast or dinner to sit on the toilet.
- Take less pain medicine if possible. Follow your surgeon's instructions for taking pain medicine.

Tip

- Laxatives and stool softeners can be purchased at most local grocery stores, drugstores and large retailers.
- Read the label carefully and follow package directions. Talk with your pharmacist if you have any questions.
- Stop taking a laxative or stool softener when your bowel movements are back to normal.

Use of constipation medicines

You may need to take a laxative to prevent constipation as long as you are taking prescription pain medicine. Common products include:

- **stimulant laxatives.** These cause the colon to have a bowel movement. This is the best choice when your constipation is caused by a prescription pain medicine. Examples include senna (Senokot®) and bisacodyl (Dulcolax®, Correctol®). Follow package directions.
- **stool softeners.** These add moisture to the stools to make the stool softer and easier to pass. These may not be enough to prevent constipation while you are taking a prescription pain medicine. An example is docusate (Colace®). Follow package directions.

When to call your primary care provider

Call your primary care provider if:

- your constipation does not improve after you have
 - made changes to what you are eating
 - made exercise changes
 - tried laxatives or stool softeners
- you have not had a bowel movement in 3 days
- you have a severe, sudden onset of abdominal pain
- you have blood in your stool.

Do you need to take preventive antibiotics before dental work?

Germ (bacteria) that can cause infections in your teeth or gums can be released into your bloodstream during some dental procedures.

To help prevent an infection, you may need to take antibiotics before dental work if you have:

- a weak immune system caused by medicines, radiation, or a disease or condition
- type 1 diabetes
- inflammatory arthritis such as rheumatoid arthritis
- blood that does not clot normally (hemophilia).

Be sure to also tell your dentist if you have ever had an infection in your artificial joint.

You may also need to take antibiotics if you need to have any of the following dental procedures:

- gum disease treatment
- one or more teeth removed
- root canal
- anesthetic injections in gums
- having artificial teeth (implants) placed
- any treatment that could cause bleeding such as cleaning.

Your dentist and surgeon will work together to decide which type of treatment is right for you.

Important

Ask your surgeon when it is OK to resume having routine dental appointments or any dental work done.

What else should you keep in mind?

Tell health care providers and dentists of your shoulder replacement surgery **before** having any surgery, podiatry procedures, dental work, X-rays, or other tests or procedures. You may need to take antibiotics.

When can you drive a car?

- Talk with your surgeon about when you can resume driving.
- You should wait to drive a car until after your first follow-up appointment with your surgeon.
- Do not drive while taking pain medicine because it can impair your judgment and ability to operate the car safely.

When can you return to work or your hobbies?

- Discuss returning to work or hobbies with your surgeon.
- Ask your occupational therapist or physical therapist how your activity restrictions will affect your hobbies.

When can you resume sexual activity?

- You can resume sexual activity when you are ready.
- A firm mattress is recommended.
- Be the passive partner for the first 6 weeks after surgery.
- Use the missionary position or less dominant position.

Will you set off metal detectors in airports?

If your shoulder replacement has metal, it will set off the metal detectors in airports. It is recommended to tell the security officer that you have a metal implant and where it is located before you go through security screening. The security officer may offer you a private security screening.

More Information

Visit recoversex.com for more information about resuming sexual activity after surgery.

Pain Medicine: What You Need to Know

Resources

Managing your pain continues when leave the hospital.

For more information on managing your pain, visit allinahealth.org/surgery to watch a series of four short videos on pain.

The topics are:

- pain expectations
- how to use the pain scale
- how to treat pain in the hospital
- how to manage pain at home.

You can watch the videos as often as you would like.

What to remember when taking pain medicines

- Many pain medicines (like Tylenol®) have acetaminophen. Pharmacists advise that you take no more than 3,000 milligrams (3 grams) of acetaminophen in 24 hours. More than that could damage your liver. Acetaminophen is also found in cough and cold medicines.
- Do not drink alcohol while taking prescription pain medicine.
- Do not drive any motor vehicles while taking opioids or prescription pain medicines that make you sleepy.
- Eat a variety of healthful foods and drink six to eight 8-ounce glasses of water each day. Eat lots of fresh fruits, raw vegetables and other foods high in fiber. This will help prevent constipation. Talk with your health care provider or pharmacist about what you can do if you are constipated.
- Taking your pain medicine with a small amount of food may be helpful to control stomach upset.

How to cut back your use of pain medicine

- Take the medicine as instructed. Take the medicine at the same time the first few days you are home.
- Cut back on the pain medicine when you think the pain is under control. You can go for longer times between doses or only take one pill instead of two. Take the medicine at the time of the day when you most often feel pain. This may be:
 - when you wake up in the morning
 - before you start certain activities
 - when you are ready for bed.

When to call your health care provider or pharmacist

- Take less of the pain medicine and call your health care provider if you have unusual feelings after taking it. This includes feeling dizzy, itchy or nauseous.
- Make sure your health care provider knows what you are taking if you take several medicines. Some medicines can be harmful when taken with others.
- Call your surgeon's office several days before the weekend if you need a prescription pain medicine refill close to the weekend. Most health care providers on call will not reorder opioids for others' patients.

Anti-inflammatory Medicines

Important

Do not take an anti-inflammatory medicine unless instructed by your surgeon.

You may have been started on anti-inflammatory medicines during your recovery in the hospital. Anti-inflammatory medicines help with healing by reducing swelling and pain. **Important: Do not take anti-inflammatory medicines unless instructed by your surgeon.**

If you will be continuing an anti-inflammatory medicine after leaving the hospital, be aware that these medicines may cause stomach upset for some people. Take the medicine as directed on your prescription. Taking this medicine with food or milk may be helpful to control stomach upset. Call your health care provider if you have any questions or concerns.

How to Use an Incentive Spirometer

Incentive spirometer

After surgery, it may be difficult to breathe as you normally do. You may notice your breathing changes to small, shallow breaths. This can cause fluid and mucus to build up in your lungs, increasing your risk for respiratory system problems (complications).

An incentive spirometer is a hand-held breathing exercise device to help you breathe deeply. Taking deep breaths allows air to inflate your lungs, opening your airways to prevent fluid and mucus buildup.

Using an incentive spirometer may speed your recovery and lower your risk of lung problems such as pneumonia.

How to use the incentive spirometer

1. Sit upright in a chair with your feet flat on the floor. (If you are not able to sit up in a chair, sit as upright as possible.)
2. Place the spirometer on your bedside table or hold it in an upright position.
3. Place the mouthpiece in your mouth. Seal your lips tightly around the mouthpiece.
4. Inhale as slowly and deeply as possible through the mouthpiece. Your health care provider will work with you to set a breathing goal, which will be marked with small arrows on the incentive spirometer. As you inhale, the small square should stay between the arrows.
5. Hold your breath for 3 to 5 seconds. Then exhale slowly through pursed lips. (Pursed lips are in the shape of blowing out a candle.)
6. Repeat 10 times, resting between each time.
7. It is important to cough to clear any secretions. Coughing (clearing your airway) will make breathing easier. It will also strengthen your muscles after each use.

How often you need to use the incentive spirometer

- **At the hospital:** You will need to use the incentive spirometer 10 times every hour you are awake after surgery.
- **At home:** You will need to use the incentive spirometer 10 times every 2 hours for your first 7 days at home.

Nutrition: What You Need to Know

Tip

According to the United States Department of Agriculture, you should:

- eat smaller portion sizes
- make half of your grains whole
- make half of your plate vegetables and fruits
- drink fat-free or low-fat milk
- eat lean proteins.

Visit choosemyplate.gov for more information about nutrition.

Important

Ask your health care provider if you have questions about your nutrition and recovery.

Tip

Be sure to drink six to eight 8-ounce glasses of liquids (especially water) each day.

Good nutrition is essential for your recovery. Eating well-balanced meals and snacks will help you recover quickly and help you feel your best. What you eat after surgery affects your well-being.

If you do not eat enough of the right foods, you will become tired and less able to take care of yourself. Be sure you make time to eat — even if you do not feel hungry.

Try to think about what your plate should look like when you are planning your meals and snacks.

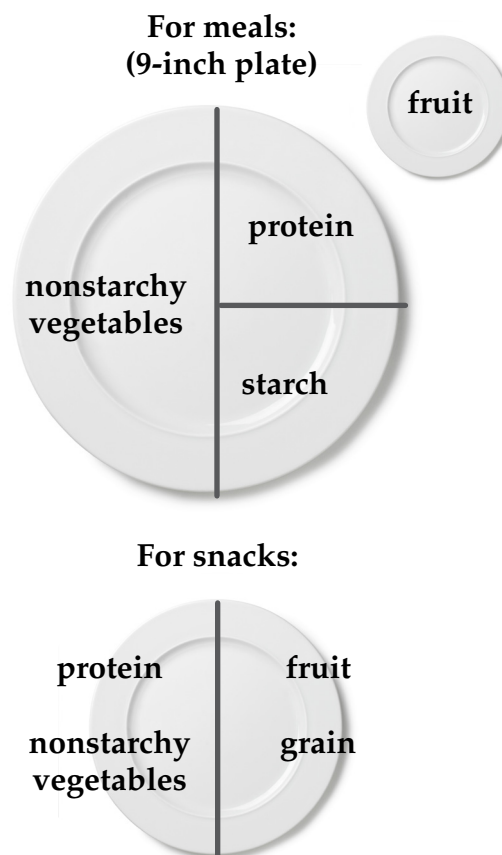

Here are some examples of well-balanced meals and a snack.

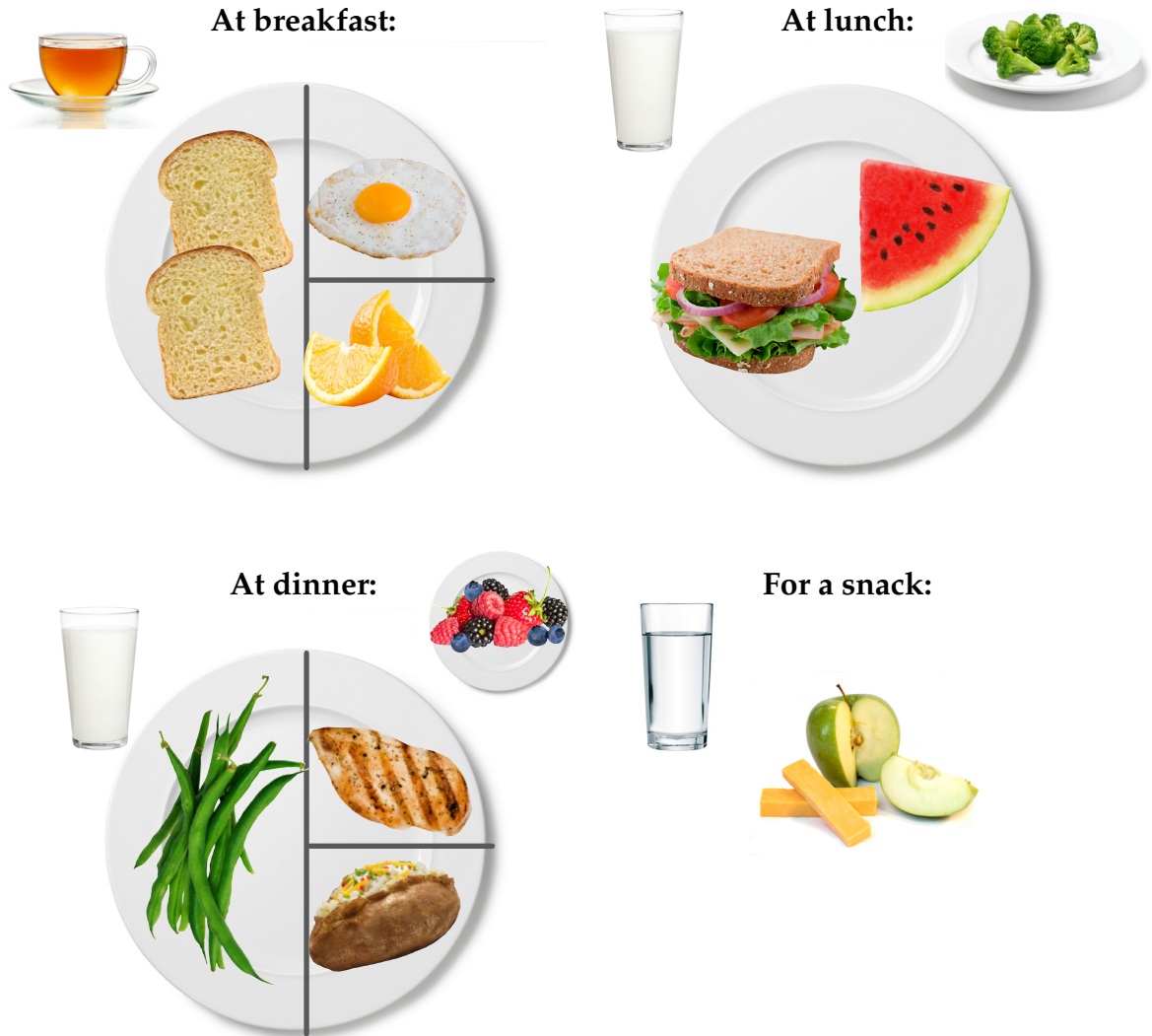

Tip

Eat foods high in vitamin C to help absorb the iron that comes from plants such as spinach.

For instance, drink a glass of orange juice with an iron-fortified cereal.

Good sources of vitamin C are oranges, broccoli, tomatoes, kiwi, strawberries, peppers, potatoes and cabbage.

























Nutrients important for your recovery

Eating foods rich in the following nutrients are important for your recovery.

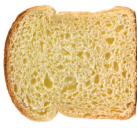
- **Protein:**
Protein helps repair and build healthy tissue.
- **Iron:**
Iron works in each of your body's cells to help make energy.
- **Vitamin C:**
Vitamin C helps your body repair damaged tissues, keeps your bones and teeth strong, and helps your body absorb iron.
- **Calcium:**
Calcium helps build and maintain your bones, your muscles move, your blood clot and your nerves send messages.
- **Fiber:**
Fiber helps your body produce regular bowel movements.

Use the chart on the next page to help you choose foods for building well-balanced meals and snacks.

The following chart shows examples of foods to put on your plate.

Protein	Iron	Vitamin C	Calcium*	Fiber**
 Chicken	 Peas	 Watermelon	 Milk	 Brown rice
 Tofu	 Raisins	 Oranges	 Yogurt	 White potato
 Eggs	 Steak	 Berries	 Green beans	 Whole-grain pasta
 Peanut butter	 Bran flakes	 Bell peppers	 Sardines	 Whole-grain bread
 Salmon	 Beans and legumes	 Grapes	 Broccoli	 Whole-grain wrap

*If you cannot tolerate milk products, you can also drink calcium-fortified juices such as orange juice. Choose low-fat or fat-free milk products.

**Choose whole-grain varieties.

Restrictions to Follow After Your Surgery



Do not push up with your surgical arm to get out of a chair.



Do not use your surgical arm to get out of bed.



Do not use your surgical arm to open/close a door.

Your shoulder replacement surgery should decrease discomfort and pain and help you return to doing activities you have not been able to do.

For the first 4 to 6 weeks after your surgery, you will wear an immobilizer on your shoulder to restrict motion and support your shoulder. You will need to wear your immobilizer all the time except when:

- doing your exercises
- showering or taking a bath
- getting dressed
- eating
- doing tabletop activities such as writing or typing.

To help the healing process with your new shoulder, your surgeon recommends that you avoid certain movements for several weeks after your surgery.

- Do not lift anything that weighs more than 1 to 2 pounds for 6 weeks after surgery.
- Do not drive until your surgeon says it is OK and when you are no longer taking prescription (opioid) pain medicines.
- If you use a walker, rest the hand of your surgical arm on the walker for balance only. Do not lean on the surgical arm for 2 months after surgery.
- Do not reach behind your back with your surgical arm to cleanse your genital or anal areas after using the toilet for 3 months after surgery.
- For 3 months after surgery, **do not** use your surgical arm to:
 - push yourself up and out of a chair or wheelchair
 - push yourself up and off of a toilet seat
 - push yourself up and out of bed
 - close doors, especially sliding glass doors.

Lifting heavy objects can cause a lot of wear on your new shoulder replacement. This can cause your artificial joint (prosthesis) to not work right over time. Talk with your surgeon about any permanent restrictions you might have after surgery.

Mobility Guidelines



Use your non-surgical arm to get off a chair.

After shoulder replacement surgery, you may need to move differently until your shoulder heals. Follow these instructions on how to move the right way after surgery.

Getting off a chair with arms

- Slide forward to the front edge of the chair.
- Put non-surgical hand on the arm rest.
- Push up with your non-surgical arm and your legs.

Getting out of bed

- You will need to get of bed on your non-surgical side.
- Do a logroll toward your non-surgical side. Turn to your side, keeping your body in a straight alignment. Your shoulders, hips and knees should all move together.
- Swing your legs over the edge of the bed as you push your upper body up with your non-surgical arm.
- Stand up slowly, pushing off with your non-surgical hand on the edge of the bed.



All photos © Allina Health System

To learn how to safely get out of bed, see the section “Getting out of bed” above.

Tip

If your immobilizer has a cushion, you may need to unbuckle it in the car so the seatbelt can fit between your body and the immobilizer. Rebuckle it once the seatbelt is in place.

Riding in a car

- If you can, sit on the side of the car so the seatbelt crosses over your non-surgical shoulder.

Using a reacher

- Use a long-handled reacher to pick up low or dropped items.

Opening and closing a door

- Get close to the door.
- Open or close the door with your non-surgical arm.

'Box of Safety'

You can safely do light activities with the "box of safety" without hurting your new shoulder.

Light activities include eating, knitting, reading and tabletop activities such as writing and typing.



Keep your hands in front of your body.

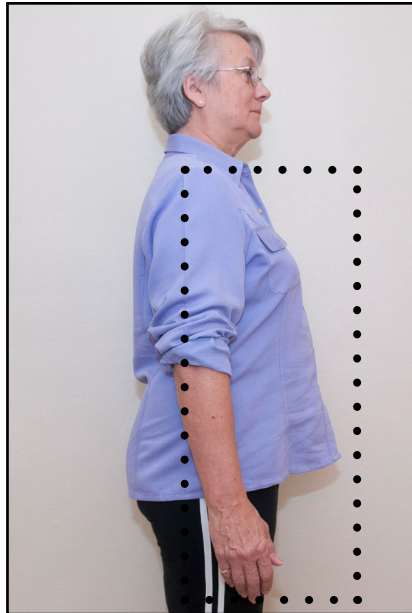

Keep your elbows at your side. Do not move them behind your body.

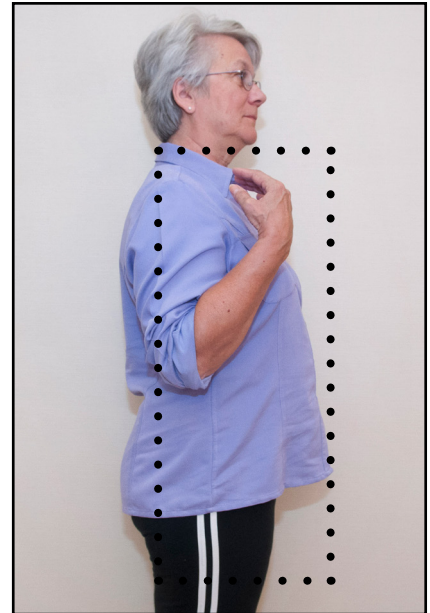

Keeping your elbow at your side, you may bend your arm at your elbow. Do not reach above your head.

All photos © Allina Health System



(Right) Light activities you can do safely include eating, knitting, reading and tabletop activities such as writing and typing.

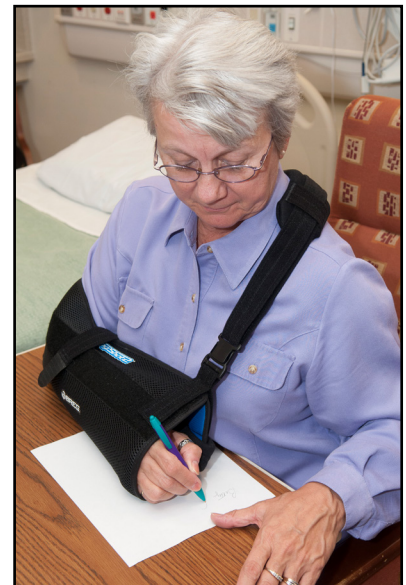

Self-care Guidelines

Follow these self-care guidelines after your shoulder replacement surgery until directed by your surgeon.

Getting dressed

It would be easiest if you can wear loose-fitting clothing like sweat pants or other loose-fitting items.

- **Shirts:** Start by dressing your surgical arm first. When getting undressed, remove clothing from your non-surgical arm first.
- **Socks:** Sit down on a chair. Using your non-surgical arm, place your thumb and fingers in the cuff of the sock and spread your fingers apart. Slip your toes into the opening of the sock and pull the sock up. Use your non-surgical arm to put your socks on both feet.
- **Bra:** If you chose to wear a bra, try to wear one that closes in the front. Place the strap over your surgical arm first. If you chose to wear a bra that closes in the back, you will need help to put it on.



© Allina Health System

When getting dressed, always start with your surgical arm first.



© Allina Health System

Using your non-surgical arm, place your thumb and fingers in the cuff of the sock and spread your fingers apart.



© Allina Health System

You can use your surgical arm to help you eat.



© Allina Health System

A raised toilet seat can help you stand up from a low toilet.



© Allina Health System

Find something sturdy to lean on when you wash your underarm.

Eating

- You can use your surgical arm to help you eat.
- You may bend your elbow and wrist and use your arm.

Using the toilet

- Put the toilet paper on your non-surgical side to make it easier to reach.
- A raised toilet seat can help you stand up from a low toilet.
- A toilet tong may help you wipe with your non-surgical arm.

Taking care of personal grooming

Here are some tips on how to brush your teeth, fix your hair or shave.

- **Brushing your teeth:** Use the hand of your non-surgical arm to hold the toothbrush. You can use your hand on your surgical arm to put the toothpaste on your toothbrush. Remember not to lift your shoulder.
- **Fixing your hair:** You will need to use your non-surgical arm to fix your hair. If you need to use your surgical arm, you can make the handle of your hair brush longer by attaching a dowel or ruler.
- **Shaving:** Use your non-surgical arm to shave. It will be easier to shave if you use an electric shaver.
- **Keeping your underarm clean:**
 - Gently lean forward. Rest your non-surgical arm on a sturdy surface. Let your surgical arm hang away from your body.
 - Wash the underarm of your surgical arm.
 - Gently pass a soapy washcloth from the front to the back. Rinse and dry the same way with a clean towel.

Home Exercise Program

Once you return home, exercise is still important.

Regular exercise:

- helps prevent problems (complications)
- makes you feel better about yourself
- helps you manage your weight
- improves muscle tone
- keeps your joints flexible
- helps you increase your activity level to what it was before surgery.

Your home exercise program will help you strengthen the weakened muscles.

Your success with rehabilitation largely depends on your commitment to follow the home exercise program (on the next page) developed by your therapists.

Your therapist will give you instructions on which exercises to do, how to do them and how many repetitions you should do each day.

Exercises after surgery

☐ Hand motions

This exercise can improve your blood flow (circulation) and reduce swelling after surgery.

- Squeeze all your fingers closed.
- Stretch all your fingers open.
- Do 10 repetitions 4 to 5 times each day.

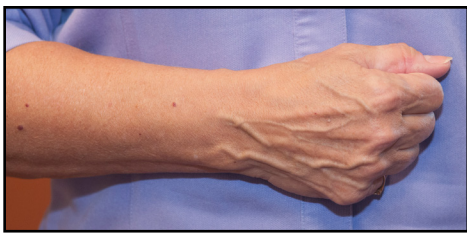

© Allina Health System

☐ Wrist motions

This exercise can keep your wrist mobile and improve your blood flow.

- You can sit, stand or lie on your back.
- Keep your arm by your side.
- Bend your wrist back and forth.
- Do 10 repetitions 4 to 5 times each day.



© Allina Health System

☐ Forearm motions

This exercise can keep your forearm mobile and improve your blood flow.

- Turn the palm of your hand up.
- Turn the palm of your hand down.
- Do 10 repetitions 4 to 5 times each day.



© Allina Health System



© Allina Health System

❑ Elbow motions

This exercise can help prevent stiffness in your elbow. Take your immobilizer off.

- Sit, stand or lie on your back with your surgical arm by your side.
- Allow your arm to relax all the way straight at your elbow.
- Raise your hand upward, bending at your elbow.
- Do 10 repetitions, 5 times each day.
- You may need your non-surgical arm to help you at first.



© Allina Health System

❑ Pendulum exercise:

This exercise will help you relax and get good motion in your shoulder.

- Find something sturdy to lean on such as a heavy chair or counter.
- Stand with your feet shoulder-width apart.
- Lean forward and support yourself with your non-surgical arm.
- Allow your surgical arm to hang loosely away from your body.
- Keeping your surgical arm relaxed, slowly swing your arm:
 - front-to-back
 - side-to-side
 - clockwise circles
 - counterclockwise circles.
- Do 10 repetitions, 4 times each day.



Chapter 6:

Resources

In This Chapter:

- Medical Equipment
- Community Resource Directory
- Worksheet: My Medicine List

Chapter 6: Resources

Medical Equipment

You may need to use some special equipment to ensure a safe recovery after your surgery. This page and the following page show and describe the equipment. Any items are optional based on your needs.

Check with your insurance provider if any equipment items will be covered by your plan. You may need to purchase or borrow equipment needed.

See the “Community Resource Directory” in this chapter for information about places that loan or sell equipment.

Raised toilet seat/ commode

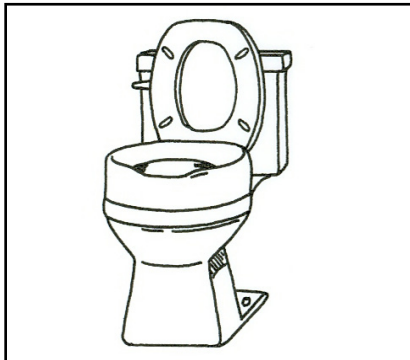

A raised toilet seat will make it easier for you to get on and off the toilet.

Toilet safety frame

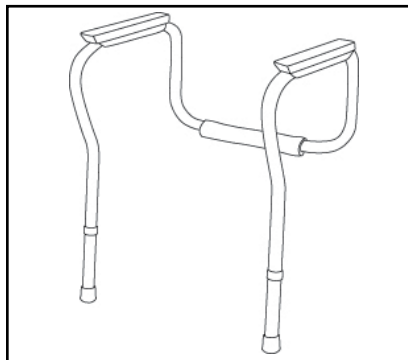

A toilet safety frame will make it easier for you to get on and off the toilet.

Grab bars

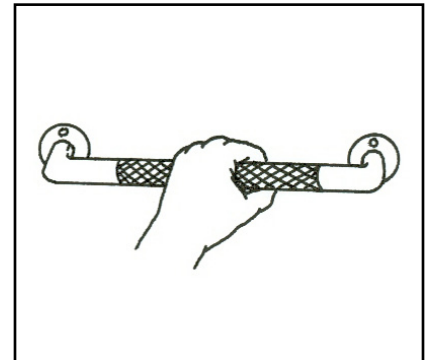

Grab bars around your toilet, bathtub or shower will increase your safety during transfers.

Tub chair

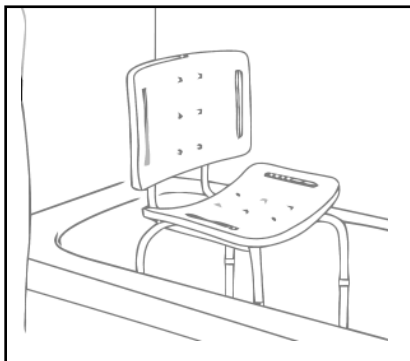

A tub chair lets you sit while taking a shower or bath.

Tub transfer bench

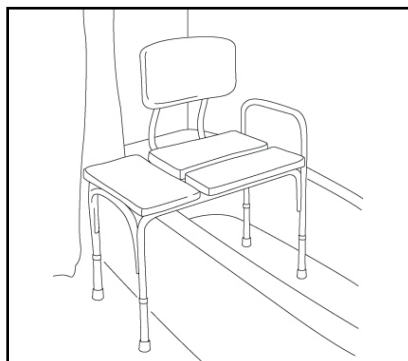

A tub transfer bench can help you get in or out of the shower or tub. You can also sit on it while taking a shower or bath.

Hand-held shower head

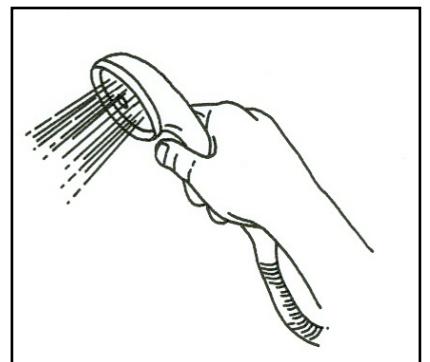

A hand-held shower head allows you to control the spray of water while sitting.

Long-handled sponge

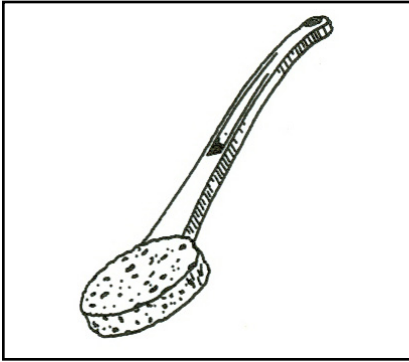

A long-handled sponge can be used to wash your feet when you cannot bend and to wash your back so you avoid twisting.

Reacher

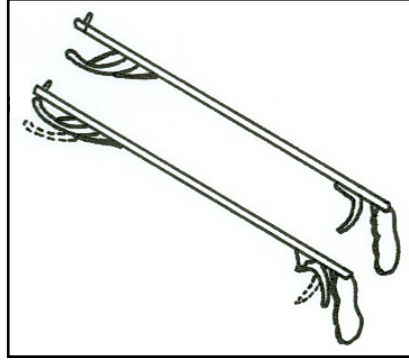

A reacher helps you get things from higher and lower levels. It can also help you put clothes on the lower part of your body.

Elastic laces/long-handled shoe horn

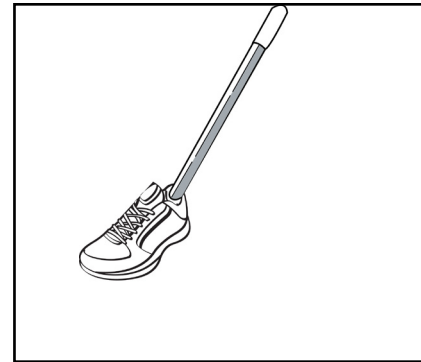

Elastic laces let you slip in and out of your shoes easily while keeping them tied. The long-handled shoe horn helps you guide your foot into an already-tied or slip-on shoe.

Tongs

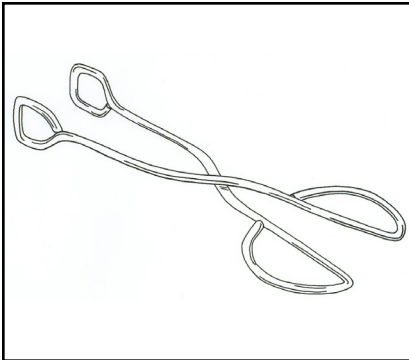

Tongs can be used in place of a reacher. Or they can help you with your hygiene care after you use the toilet.

Cane

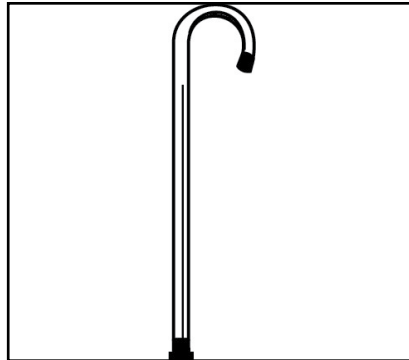

A cane may help with balance. Balance issues can happen because you have limited movement in your surgical arm. Do not use a cane with your surgical arm until your surgeon says it is OK.

Community Resource Directory

Medical equipment

Certain equipment can make your recovery go easier and increase your independence after your surgery. Try to get your equipment before you have surgery. You may want to borrow the items from family or friends if possible.

The following is a list of resources to help you find the equipment you need.

- Allina Health Home Oxygen & Medical Equipment offers items to purchase. Call 651-628-4800 or 1-800-737-4473 for information about medical equipment, supplies and services.
- Call your local American Legion, VFW or Lions Club. They often have equipment you can borrow if you are a member.
- Call your local pharmacy to see what selection of equipment that store carries.
- Look in your Yellow Pages or go to yellowpages.com and look under “handicapped services or equipment” or “home care services.”
- WisTech can connect you with resources for medical equipment in Wisconsin. Visit wisconsinat4all.com to find equipment in your area. You will need to create an account to view available items. Once you have an account, you can buy, rent or get free items from state agencies, private businesses, lending programs or individuals. Each group or individual has different criteria for using their equipment. Contact information is listed for each item.

Allina Health Care Navigation Help Desk

Call 612-262-2200 or 1-855-227-5111 if you have questions about community resources, medical equipment, home care, a transitional care unit (TCU) or a short-term rehabilitation center.

Grocery delivery

■ Twin Cities Metro Area Meals on Wheels

Volunteers deliver ready-to-eat meals to homes in most of the Minneapolis and St. Paul metro area. You can sign up for short- or long-term meal delivery if you are recovering from surgery or illness. The price is based on your need. Call 612-623-3363 or visit meals-on-wheels.com for more information or to sign up for this service.

■ Home-delivered Meals (Meals on Wheels)

Wisconsin's Elderly Nutrition Program offers meals to anyone age 60 and older. Meals can be delivered to your door Monday through Friday. Visit gwaar.org to learn more about home-delivered meals. Click *For Seniors and Families* and then *Elderly Nutrition Program*. Select *Contact someone* to find your local agency and its contact information.

- Many grocery stores and organizations offer services that will deliver healthful meals to your home. Ask a member of your health care team for more information.

Directions for My Medicine List

1. ALWAYS KEEP THIS FORM WITH YOU. You may want to fold it and keep it in your wallet along with your driver's license. Then it will be available in case of an emergency.
2. Write down all of the medicines you are taking and list all of your allergies. Add information on medicines taken in clinics, hospitals and other health care settings — as well as at home.
3. Take this form with you on all visits to your clinic, pharmacy, hospital, physician, or other providers.
4. WRITE DOWN ALL CHANGES MADE TO YOUR MEDICINES on this form. When you stop taking a certain medicine, write the date it was stopped. If help is needed, ask your doctor, nurse, pharmacist, or family member to help you keep it up-to-date.
5. In the “Notes” column, write down why you are taking the medicine (Examples: high blood pressure, high blood sugar, high cholesterol).
6. When you are discharged from the hospital, someone will talk with you about which medicines to take and which medicines to stop taking. Since many changes are often made after a hospital stay, a new list may be filled out. When you return to your doctor, take your list with you. This will keep everyone up-to-date on your medicines.

How does this form help you?

- This form helps you and your family members remember all of the medicines you are taking.
- It provides your doctors and other providers with a current list of ALL of your medicines. They need to know the herbals, vitamins, and over-the-counter medicines you take!
- With this information, doctors and other providers can prevent potential health problems, triggered by how different medicines interact.



For copies of the My Medicine List and a brochure with more tips, visit the Minnesota Alliance for Patient Safety's Web site at www.mnpatientsafety.org or call (651) 641-1121.

Get better communication and faster answers online with your Allina Health account.

Health is a journey that happens beyond the walls of your clinic or hospital and we will be there to help you – whether it's a question that pops into your head at midnight or recalling the date of your last tetanus shot. When you sign up for an Allina Health account online, you get better communication with your clinic, hospital and provider; faster answers and your (and your loved one's) health information organized and at your fingertips anytime.



Sign up for your account at allinahealth.org

**Availability varies by location. Ask your clinic or hospital if this service is available.*

S410726A 162301 1016 ©2016 ALLINA HEALTH SYSTEM. TM – A TRADEMARK OF ALLINA HEALTH SYSTEM.



Your account is a free service of Allina Health

Nondiscrimination in Health Programs and Activities

Affordable Care Act – Section 1557

Allina Health complies with applicable federal civil rights laws and does not discriminate on the basis of race, color, national origin, age, disability, gender identity or sex. Allina Health does not exclude people or treat them differently because of race, color, national origin, age, disability, gender identity or sex.

Allina Health:

- provides free aids and services to people with disabilities to communicate effectively with us, such as:
 - ◊ qualified sign language interpreters, and
 - ◊ written information in other formats (large print, audio, accessible electronic formats, other formats)
- provides free language services to people whose primary language is not English, such as:
 - ◊ qualified interpreters, and
 - ◊ information written in other languages.

If you need these services, ask a member of your care team.

If you believe that Allina Health has failed to provide these services or discriminated in another way on the basis of race, color, national origin, age, disability, gender identity or sex, you can file a grievance with:

Allina Health Grievance Coordinator
P.O. Box 43
Minneapolis, MN 55440-0043
Phone: 612-262-0900
Fax: 612-262-4370
GrievanceCoordinator@allina.com

You can file a grievance in person or by mail, fax or email. If you need help filing a grievance, the Allina Health Grievance Coordinator can help you.

You can also file a civil rights complaint with the U.S. Department of Health and Human Services, Office for Civil Rights, electronically through the Office for Civil Rights Complaint Portal, available at <https://ocrportal.hhs.gov/ocr/portal/lobby.jsf>, or by mail or phone at:

U.S. Department of Health and Human Services
200 Independence Avenue, SW Room 509F, HHH Building
Washington, D.C. 20201
1-800-368-1019, 800-537-7697 (TDD)

Complaint forms are available at <http://www.hhs.gov/ocr/office/file/index.html>.





allinahealth.org